

# Open Access Lockers – 70000 Series Installation Instructions

Thank you for selecting Salsbury's open access lockers. We are confident that the quality and construction of the lockers will prove to be a good investment. These instructions are intended to assist you in a standard open access locker with locked compartment and foot locker installation. Individual job conditions will dictate the type of fasteners and whether the lockers must be anchored to the wall, the floor, or both.

## Typical Assembly

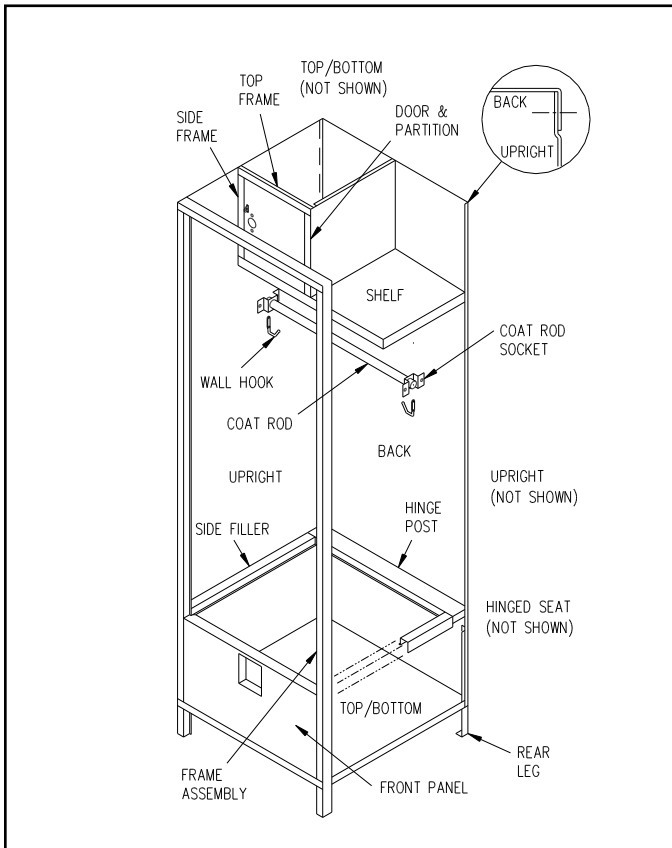

## Notes

All bolted connections should be finger tight initially. Square locker before tightening all connections.

Adjust all doors to operate freely if required.

If built-in locks are installed, make certain locks operate properly before closing doors.

## Instructions

1. Assemble left upright to back.
2. Add top/bottom to the back and upright at the top. (Heads of the bolts on the outside with the nuts to the inside).
3. Attach locked compartment left side frame to upright and top. (Heads of the bolts on the outside and locker top).
4. Assemble door and partition assembly to back and top. (Door has spring hinges). Note: Lay door over side frame hook on the side frame and line up holes in the top and back. Bolt from the outside of the locker with the nuts to the inside.
5. Add the locked compartment top frame to the left side frame and to the door partition assembly.
6. Attach shelf underneath the locked compartment to the upright, back and partition.
7. Attach the hinge post assembly to the back and left upright.
8. Bolt hinge seat to hinge post. (Nuts on the inside of the hinge seat).
9. Attach top/bottom to the back and upright at the bottom. (Heads of the bolts on the outside with the nuts to the inside).
10. Attach right upright, coat rod socket, hooks and coat rod. (Heads of the bolts on the outside with the nuts to the inside).
11. Attach front panel to frame assembly. (Heads of the bolts on the inside of the front panel with the nuts on the inside of the frame).
12. Bolt frame assembly with the front panel to the assembled locker body. (Heads of the bolts on the outside with the nuts to the inside).
13. Add side fillers to the sides of both uprights. (Make sure the return flange of the side fillers are on top of the rear hinge post flange and the top of the front panel).

[www.Communitymailboxes.com](http://www.Communitymailboxes.com)

Phone: 1 888 863 1040 Fax: 1 707 265 0206

Installation instructions are provided as general guidelines. It is advised that a professional installer be consulted. Communitymailboxes assumes no product assembly or installation liability

# Open Access Lockers – Locker Benches

## Assembly & Installation Instructions

Thank you for selecting Salsbury's 77770 series locker aluminum benches. We are confident that the quality and construction of this product will provide years of maintenance free use.

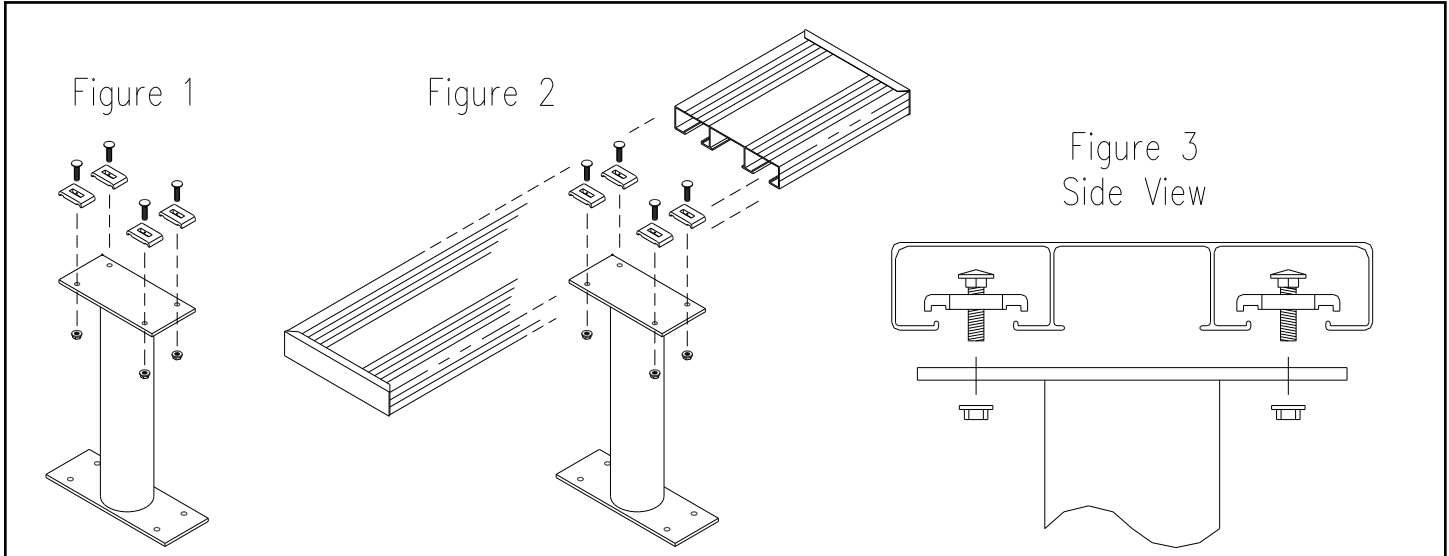

### Preliminary Notes

There are two basic steps to assembly and installation:

1. The bench pedestals must be assembled to the bench top.
2. The bench assembly must be bolted to the floor.

***Failure to bolt the bench assembly to the floor could result in injury to persons sitting on the bench.***

Since various types of floors require different types of fasteners, floor installation hardware is not provided. The hardware provided is for fastening the bench pedestals to the bench top.

Two bench pedestals are provided for each bench top. Each bench pedestal should be installed 6" from the end of each side of the bench top.

### Assembly

Install one of the 5/16" by 1-1/4" long carriage bolts through a straddle clamp and loosely attach it to the bench pedestal with one of the 5/16" serrated flange nuts as shown in Figure 1. The straddle clamps should be installed on the end of the bench pedestal with the smaller plate. Do this with the remaining three straddle clamps in the first bench pedestal and repeat for the four clamps in the second bench pedestal.

Set the bench top on a flat surface upside down. Rotate each of the straddle clamps on a bench pedestal aligned such that they can be inserted into the bottom of the bench top as shown in Figure 2. Rotate them each 90 degrees so that they straddle and grip the inside lips of the bench top when the nuts are tightened as shown in Figure 3. Ensure that the straddle clamps are aligned with the lips. Also ensure that the square section of the carriage bolts are inside the square slots in the straddle clamps. Tighten the nuts until the clamps are not quite gripping the lips inside the bench top. Slide the bench pedestal to a position 6" from one end of the bench top. Adjust the position of the bench pedestal so that it is centered crosswise under the bench top and tighten the nuts securely.

Repeat for the other bench pedestal, installing it 6" from the other end of the bench top.

***Complete the installation by fastening the assembled bench to the floor.***

[www.Communitymailboxes.com](http://www.Communitymailboxes.com)

Phone: 1 888 863 1040 Fax : 1 707 265 0206

Installation instructions are provided as general guidelines. It is advised that a professional installer be consulted. Communitymailboxes assumes no product assembly or installation liability