

Standard Lockers – 61000 Series

Single Tier Installation Instructions

Thank you for selecting Salsbury's standard single tier lockers. We are confident that the quality and construction of the lockers will prove to be a good investment. These instructions are intended to assist you in a typical wall anchored locker installation. Individual job conditions will dictate the type of fasteners and whether the lockers must be anchored to the wall, the floor, or both.

Typical Assembly

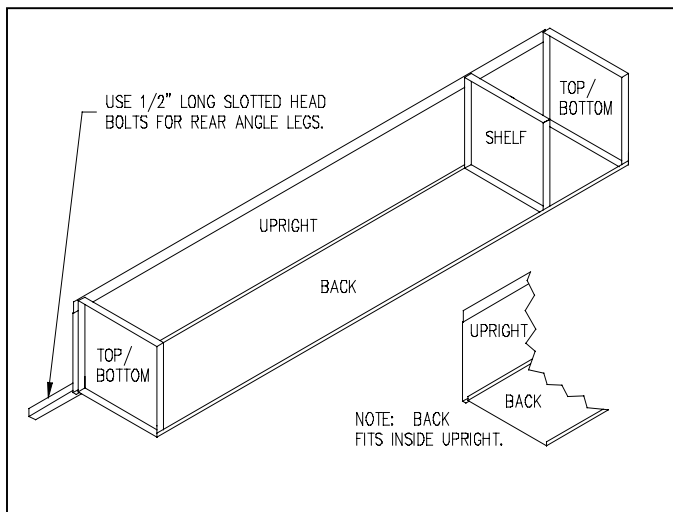

Typical Installation

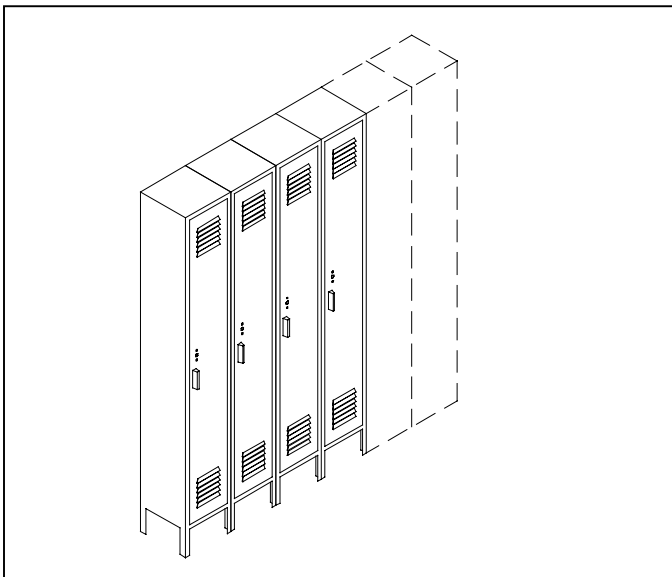

Notes

When lockers are set in place, care must be taken to assure lockers are set plumb and true before anchoring.

Lockers are not designed as free-standing structures. Lockers must be anchored securely to walls and/or floors with fasteners.

WARNING: Failure to properly anchor lockers could cause them to topple.

Adjust all doors to operate freely if required.

If built-in locks are installed, make certain locks operate properly before closing doors.

Assembly of Single Row Lockers

1. Lay down the back panel with the flanges facing up and the two closer leg mounting holes at the bottom. Loosely attach the Leg with the wider flange against the back panel, using two bolts and nuts. Loosely attach the second leg to the opposite side of the back panel in the same manner.
2. Attach one upright panel to the outside of the flange of the back panel. Note that back fits "inside" upright. Align the holes and secure with bolts and nuts.
3. Bolt the top and the bottom to the upright panel. Make certain that their fronts are in the correct position. Secure the second upright panel to the unit, keeping it on the outside of the back panel. Bolt the shelves to the sides.
4. Place the door frame over the assembled locker and fasten. Make certain that the sides are inside the door frame.
5. Carefully raise the locker to an upright position. Square and level the cabinet, then tighten all nuts and bolts.

www.Communitymailboxes.com

Phone: 1 888 863 1040 Fax : 1 707 265 0206

Installation instructions are provided as general guidelines. It is advised that a professional installer be consulted. Communitymailboxes assumes no product assembly or installation liability

Standard Lockers – Locker Benches

Assembly & Installation Instructions

Thank you for selecting Salsbury's 77770 series locker aluminum benches. We are confident that the quality and construction of this product will provide years of maintenance free use.

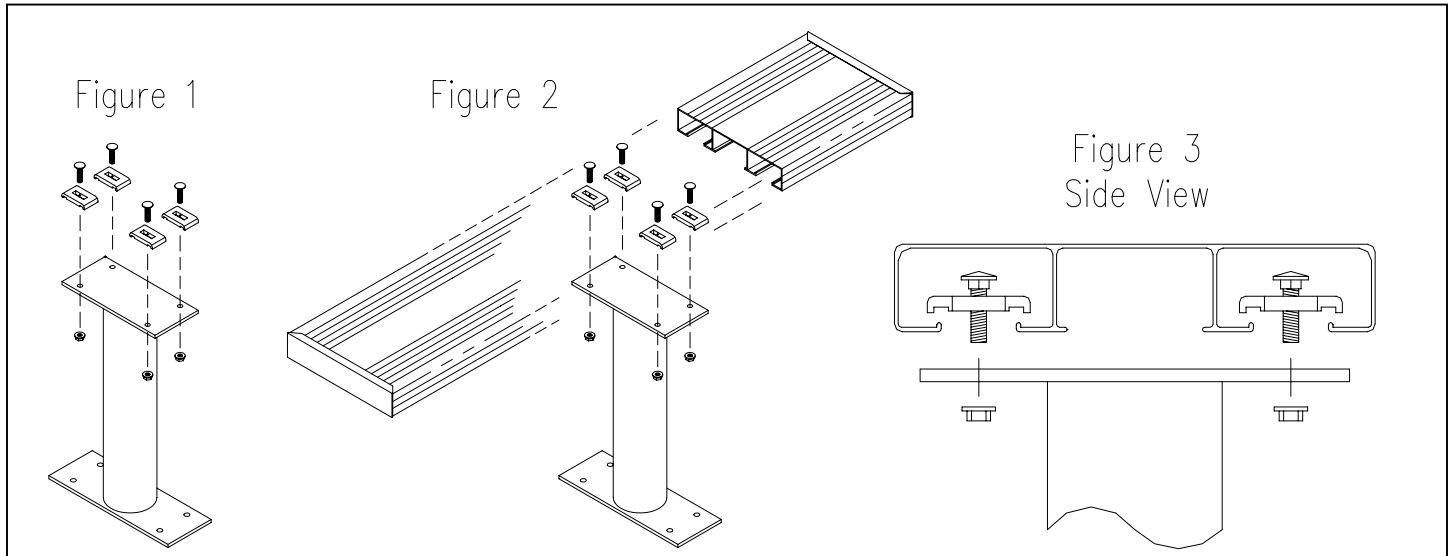

Preliminary Notes

There are two basic steps to assembly and installation:

1. The bench pedestals must be assembled to the bench top.
2. The bench assembly must be bolted to the floor.

Failure to bolt the bench assembly to the floor could result in injury to persons sitting on the bench.

Since various types of floors require different types of fasteners, floor installation hardware is not provided. The hardware provided is for fastening the bench pedestals to the bench top.

Two bench pedestals are provided for each bench top. Each bench pedestal should be installed 6" from the end of each side of the bench top.

Assembly

Install one of the 5/16" by 1-1/4" long carriage bolts through a straddle clamp and loosely attach it to the bench pedestal with one of the 5/16" serrated flange nuts as shown in Figure 1. The straddle clamps should be installed on the end of the bench pedestal with the smaller plate. Do this with the remaining three straddle clamps in the first bench pedestal and repeat for the four clamps in the second bench pedestal.

Set the bench top on a flat surface upside down. Rotate each of the straddle clamps on a bench pedestal aligned such that they can be inserted into the bottom of the bench top as shown in Figure 2. Rotate them each 90 degrees so that they straddle and grip the inside lips of the bench top when the nuts are tightened as shown in Figure 3. Ensure that the straddle clamps are aligned with the lips. Also ensure that the square section of the carriage bolts are inside the square slots in the straddle clamps. Tighten the nuts until the clamps are not quite gripping the lips inside the bench top. Slide the bench pedestal to a position 6" from one end of the bench top. Adjust the position of the bench pedestal so that it is centered crosswise under the bench top and tighten the nuts securely.

Repeat for the other bench pedestal, installing it 6" from the other end of the bench top.

Complete the installation by fastening the assembled bench to the floor.

www.Communitymailboxes.com

Phone: 1 888 863 1040 Fax : 1 707 265 0206

Installation instructions are provided as general guidelines. It is advised that a professional installer be consulted. Communitymailboxes assumes no product assembly or installation liability.