

Collection Boxes – 4900 Series

Installation Instructions

Thank you for selecting the 4900 series collection box. The heavy-duty unit is constructed of 16 gauge steel and features a durable powder coat finish. It provides the utmost in security and can withstand severe weather conditions. We are confident that the quality and construction of the collection boxes will prove to be a good investment. The units are fully assembled and ready to be installed. If the 4900 collection box is ordered with a snorkel, it is installed at the factory. No further assembly is required.

Model 4900 Collection Box

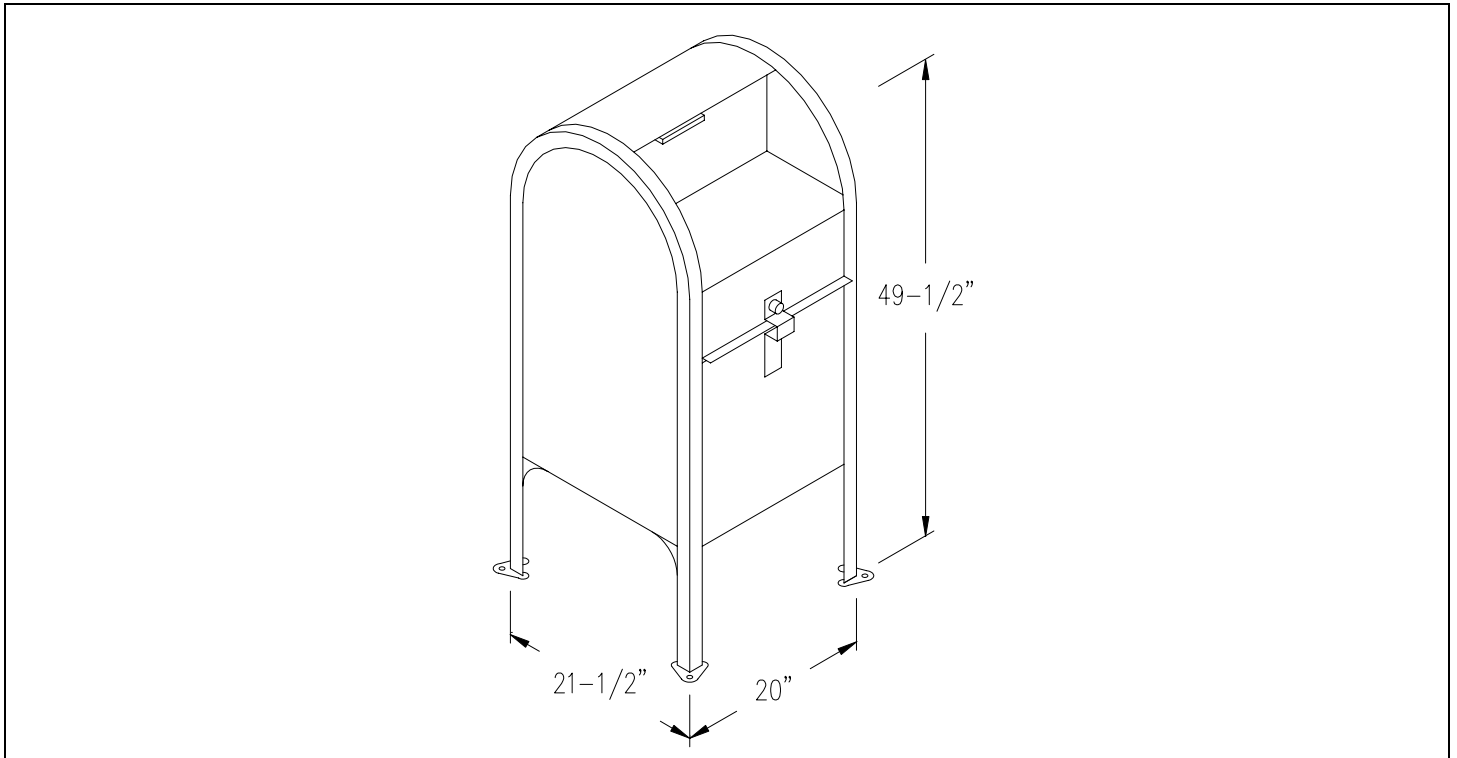

Installation

Due to the various types of surfaces on which the collection box might be ultimately mounted, there is no installation hardware included with the unit. Select and procure the bolts and anchors according to the type of surface, be it wood, cement, or another material. In certain applications, it may not be necessary or desirable to fasten the unit down. However, before this decision is made, carefully consider the security of the collection box.

There is one 9/16" diameter hole in each of the four feet in the 4900 collection box to fasten the unit down to the surface on which it is placed. Lag screws with or without expansion anchors or bent anchor bolts (buried in concrete) with nuts may be used to fasten the units down, as an example. Suggested size is 3/8" diameter bolts.

A standard padlock (sold separately) is required to lock the lower door of the 4900 collection box.

www.Communitymailboxes.com

Phone: 1 888 863 1040 Fax : 1 707 265 0206

Installation instructions are provided as general guidelines. It is advised that a professional installer be consulted. Communitymailboxes assumes no product assembly or installation liability