

Deluxe Mailbox Posts – 4870 and 4880

Deluxe Arm Post Installation Instructions

Installing Arm(s) on Deluxe Mailbox Posts

Thank you for selecting Salsbury's deluxe mailbox post. We are confident that the quality and construction of the post will prove to be a good investment. This instruction sheet is for assembling the 1-sided or 2-sided deluxe mailbox post.

4870 – 1 Sided

First check to see that all the parts and fasteners in the carton have been located and identified according to the illustration below. Also refer to the illustration below to position the parts correctly.

1. Attach the small right-angle bracket to the post with the long leg on top with two (2) 5/16" x 1" long hex washer-head bolts.
2. Attach the long square-tube arm to the small right angle bracket with two (2) 1/4"-20 x 1/2" long flat-head socket screws.
3. Attach the large decorative arch to the post and the long arm with four (4) 5/16" x 1" long hex washer-head bolts.
4. Attach the other small right-angle bracket with the long leg on the bottom with two (2) 5/16" x 1" long hex washer-head bolts.
5. Attach the short square-tube arm to the small right-angle bracket with two (2) 1/4"-20 x 1/2" long flat-head socket screws. This completes the assembly.

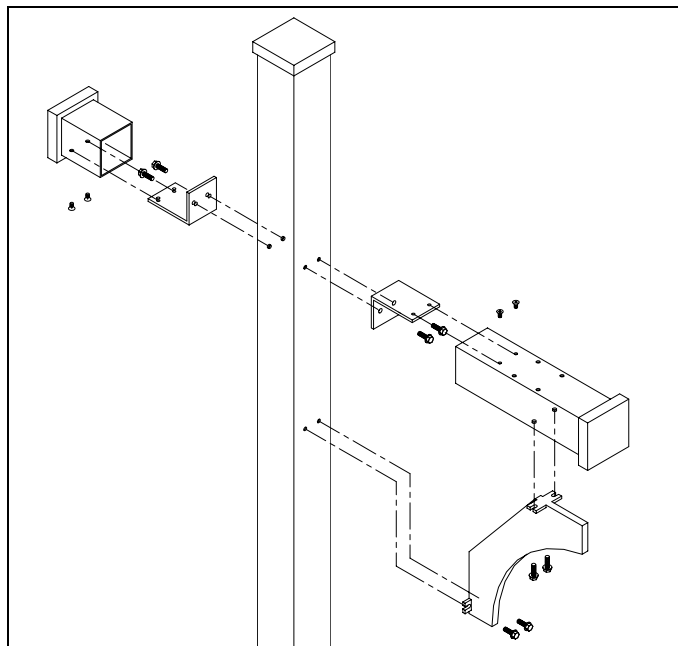

4870 Assembly

When you install a curbside or rural mailbox, make sure that it is easily accessible to the mail carrier. By regulation it should be 41" to 45" from the ground or street surface up to the inside floor of the mailbox. The door should be set 6" to 8" back from the front face of the curb or the road edge. However, check with your postmaster to ensure that the mailbox is installed according to local regulations.

4880 – 2 Sided

First check to see that all the parts and fasteners in the carton have been located and identified according to the illustration below. Also refer to the illustration below to position the parts correctly.

1. Attach the small right-angle bracket to the post with the long leg on top with two (2) 5/16" x 1" long hex washer-head bolts.
2. Attach the long square-tube arm to the small right angle bracket with two (2) 1/4"-20 x 1/2" long flat-head socket screws.
3. Attach the large decorative arch to the post and the long square-tube arm with four (4) 5/16" x 1" long hex washer-head bolts.
4. Repeat steps 1 through 3 above for the second arm on the other side of the post. This completes the assembly.

General Note: Use the four (4) hex-head bolts provided to install the mailbox to the deluxe post. The 1" thick aluminum spacer installs between the bottom of the Salsbury 4850 mailbox and the top of the deluxe post arm.

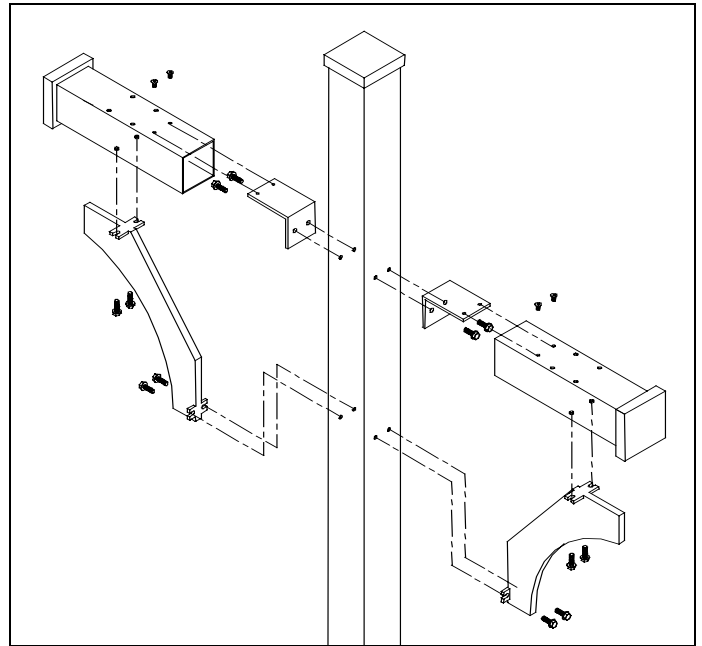

4880 Assembly

www.Communitymailboxes.com

Phone: 1 888 863 1040 Fax : 1 707 265 0206

Installation instructions are provided as general guidelines. It is advised that a professional installer be consulted. Communitymailboxes assumes no product assembly or installation liability

Deluxe Mailbox Posts – 4870 and 4880

In-Ground Mounted Post Installation Instructions

Installing the In-Ground Mounted Post for the Mailbox Into Concrete

When you install a curbside or rural mailbox, make sure that it is easily accessible to the mail carrier. By regulation it should be 41" to 45" from the ground or street surface up to the inside floor of the mailbox. The door should be set back 6" to 8" back from the front face of the curb or the road edge. However, you should check with your local postmaster to ensure that the mailbox is installed according to local regulations.

Dig the hole for the concrete footing, and prepare the concrete. You will need approximately 4-1/2 cubic feet. The top surface of the footing should be about 12" by 18" and extend 36" into the ground. See the illustration for the relative position of the rectangular footing to the post and mailbox. The bottom of the hole for the concrete footing should be filled with about 6" of gravel to promote drainage under the post. The top of the footing should be sloped for water runoff.

The concrete must be below the frost line. Otherwise the post will move when the ground freezes. Be careful not to puncture water, sewer, or gas lines when digging holes for footing.

Set the post in the hole and fill the hole with the prepared concrete mix. Prod the mix with a stick while filling to reduce any air pockets. If you want to conceal the concrete, pour it to within a few inches of the top of the hole and cover with soil after the concrete has set. Use a carpenter's level on the sides of the post to ensure that the post is aligned vertically. Periodically check the vertical alignment of the post as the concrete is curing.

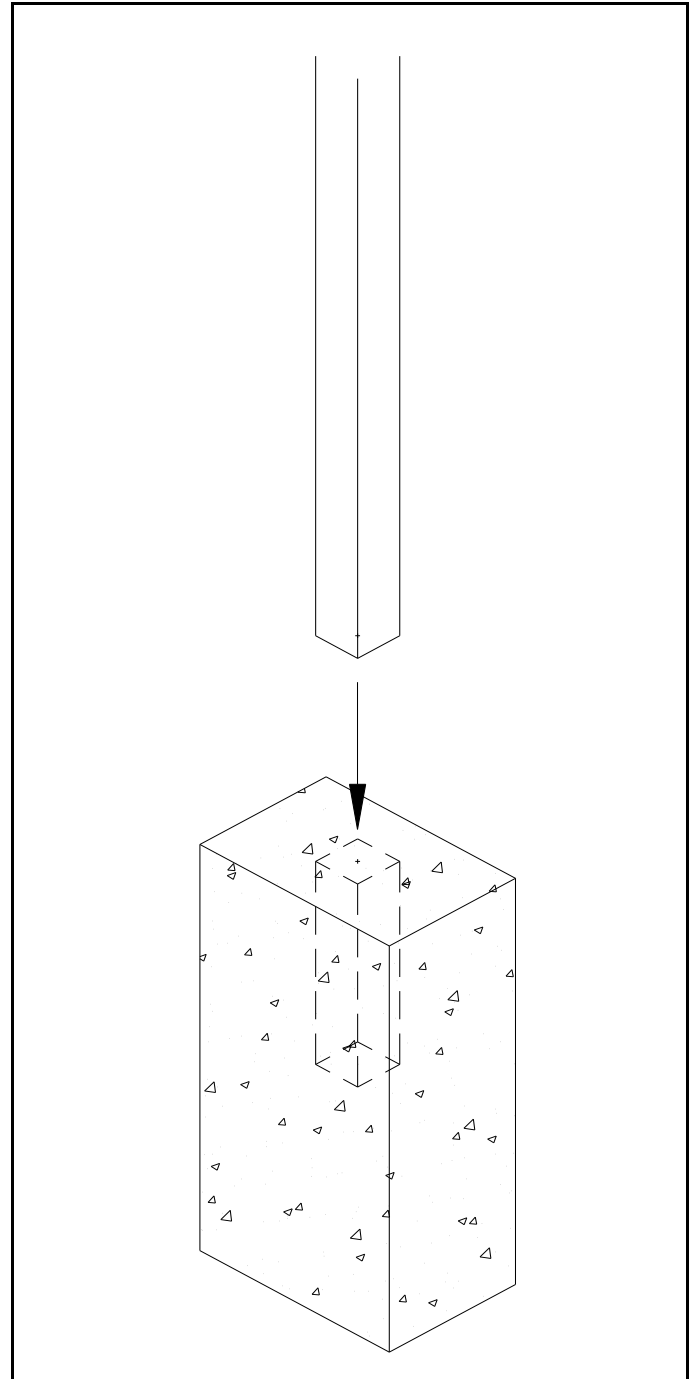

www.Communitymailboxes.com

Phone: 1 888 863 1040 Fax : 1 707 265 0206

Installation instructions are provided as general guidelines. It is advised that a professional installer be consulted. Communitymailboxes assumes no product assembly or installation liability