

Standard Mailbox Posts – 4800 Series

Installation Instructions

Installing Mailbox on a Standard Mailbox Post

Thank you for selecting Salsbury's standard mailbox post. We are confident that the quality and construction of the post will prove to be a good investment. This instruction sheet is for installing the Salsbury 4850 mailbox on a Salsbury standard mailbox post.

When you install a curbside or rural mailbox, make sure that it is easily accessible to the mail carrier. By regulation it should be 41" to 45" from the ground or street surface up to the inside floor of the mailbox. The door should be set back 6" to 8" back from the front face of the curb or the road edge. However, you should check with your local postmaster to ensure that the mailbox is installed according to local regulations.

The top plate of the standard rural mailbox post has four tapped holes. There are four 5/16" hex washer head bolts provided with the post to attach the mailbox to the post. Open the front door of the mailbox and install the four hex washer head bolts through the four holes in the inside floor of the mailbox and through the four tapped holes on the top plate of the standard rural mailbox post.

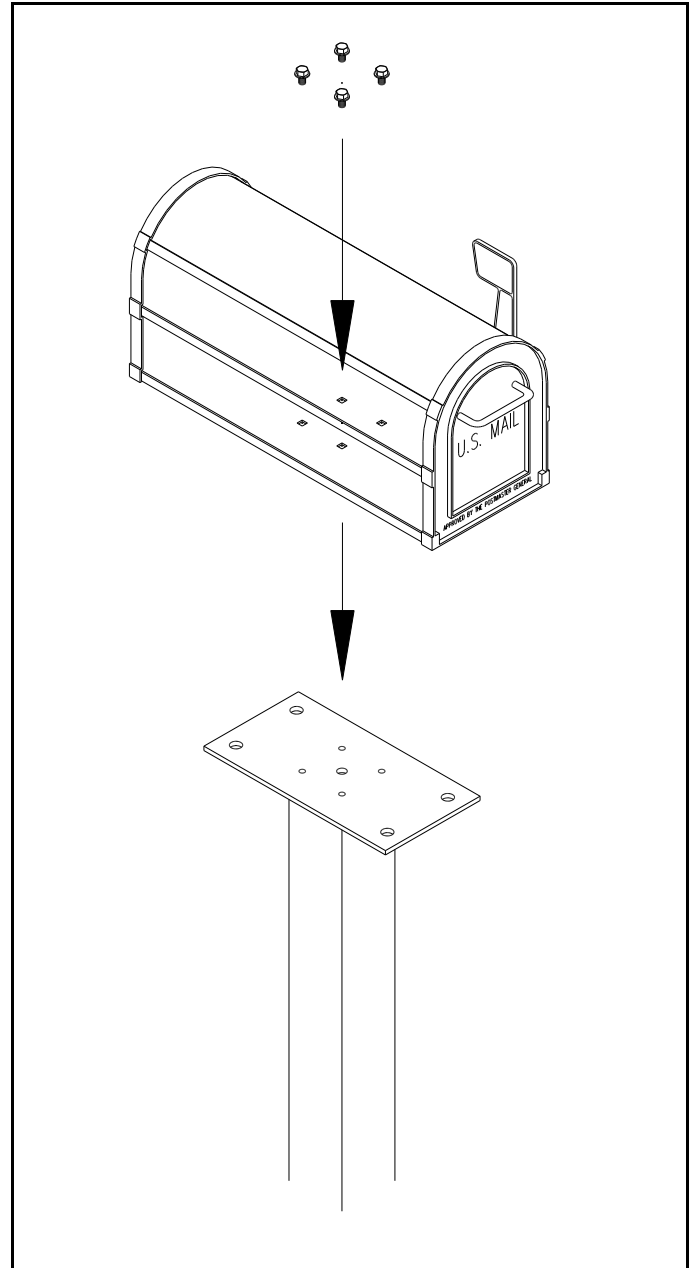

www.Communitymailboxes.com

Phone: 1 888 863 1040 Fax : 1 707 265 0206

Installation instructions are provided as general guidelines. It is advised that a professional installer be consulted. Communitymailboxes assumes no product assembly or installation liability

Standard Mailbox Posts – 4800 Series

Bolt Mounted Post Installation Instructions

Installing the Bolt Mounted Post for the Mailbox onto Anchor Bolts

When you install a curbside or rural mailbox, make sure that it is easily accessible to the mail carrier. By regulation it should be 41" to 45" from the ground or street surface up to the inside floor of the mailbox. The door should be set back 6" to 8" back from the front face of the curb or the road edge. However, you should check with your local postmaster to ensure that the mailbox is installed according to local regulations.

Dig the hole for the concrete footing, and prepare the concrete. You will need approximately 4-1/2 cubic feet. The top surface of the footing should be about 12" by 18" and extend 36" into the ground. See the illustration for the relative position of the rectangular footing to the post and mailbox. The bottom of the hole for the concrete footing should be filled with about 6" of gravel to promote drainage under the post. The top of the footing should be sloped for water runoff.

The concrete must be below the frost line. Otherwise the post will move when the ground freezes. Be careful not to puncture water, sewer, or gas lines when digging holes for footing.

Attach the 4 J-shaped anchor bolts to the base of the post with 4 nuts under and 4 nuts over the bottom mounting plate. Pour the concrete into the hole, prodding the mix with a stick while filling to reduce any air pockets. Press the anchor bolts on the bottom of the post into the concrete until the bottom plate is resting on the top surface of the wet concrete. Use a carpenter's level on the sides of the post to ensure that the post is aligned vertically. Periodically check the vertical alignment of the post as the concrete is curing.

The concrete will shrink as it hardens, leaving a space between the anchor and the concrete when it is cured. To prevent this, loosen the top bolt one full turn prior to inserting into the wet concrete. After the anchor is inserted into the wet concrete, place your foot on the top of the threaded anchor and push down until the top nut is pressed against the anchor plate. After the concrete has hardened, re-tighten the top bolt.

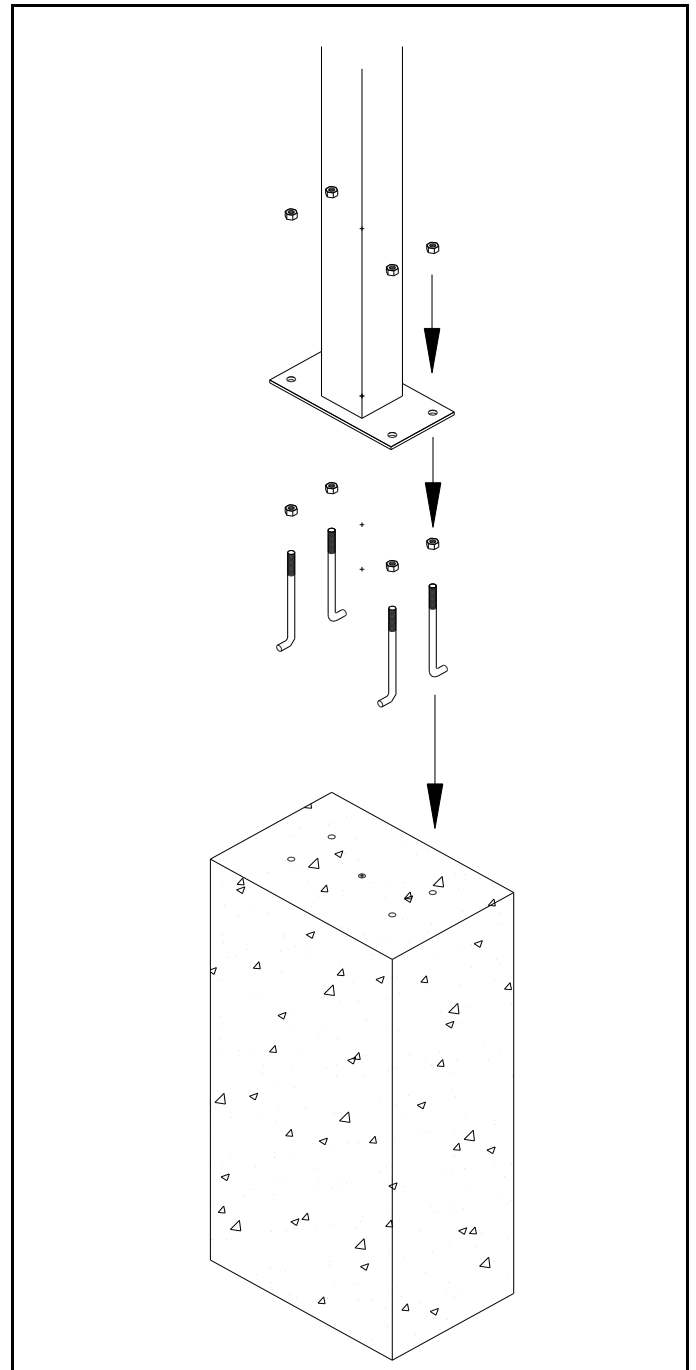

www.Communitymailboxes.com

Phone: 1 888 863 1040 Fax: 1 707 265 0206

Installation instructions are provided as general guidelines. It is advised that a professional installer be consulted. Communitymailboxes assumes no product assembly or installation liability.