

# Mail Houses – 4750

## Post Mounting Installation Instructions

Made of electro-galvanized steel sheet with a durable powder coat finish and a stainless steel mail flap, Salsbury 4750 mail houses will provide years of maintenance free service.

### Mounting Mail House on a Post

This instruction sheet is for installing the 4750 mail house on a Salsbury standard mailbox post. Other installation instructions are available for mounting the post in a concrete footing or mounting the unit to a wall.

The top plate of the standard mailbox post has four tapped holes. There are four 5/16" hex washer head bolts provided with the post to attach the mailbox to the post. Open the locked front door and install the four hex washer head bolts through the four holes in the inside floor of the mailbox to the top plate of the standard mailbox post.

4750 Mail House

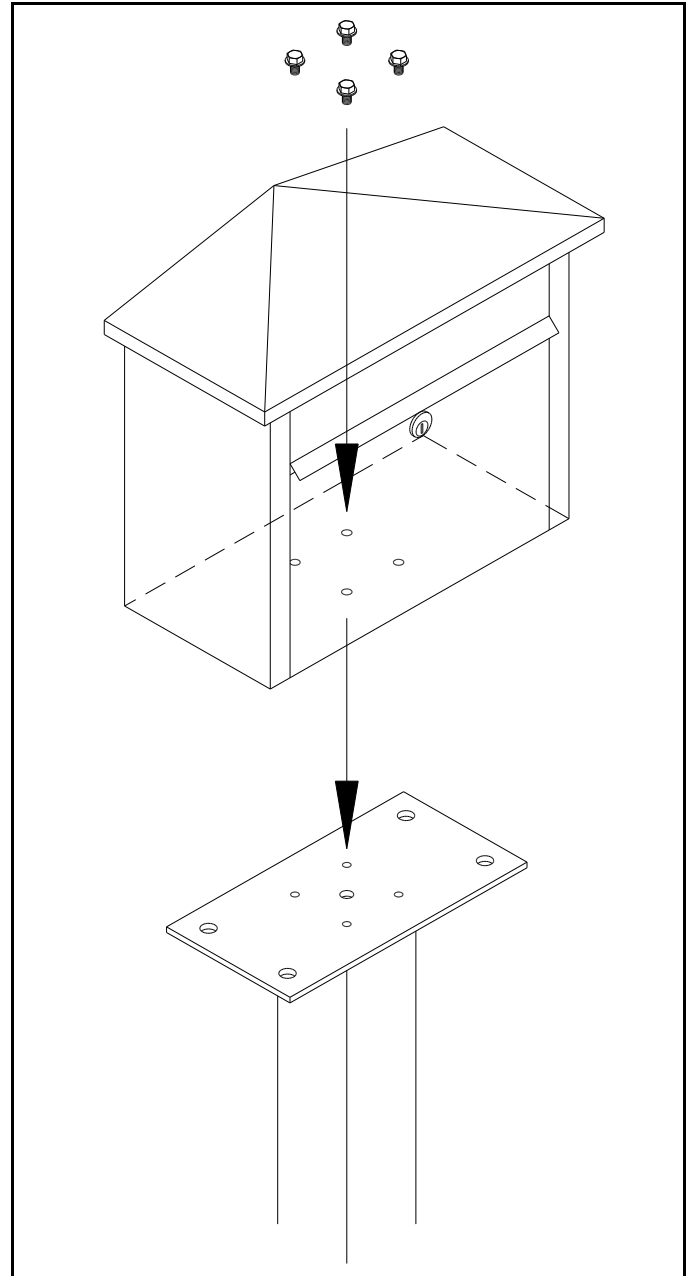

[www.Communitymailboxes.com](http://www.Communitymailboxes.com)

Phone: 1 888 863 1040 Fax : 1 707 265 0206

Installation instructions are provided as general guidelines. It is advised that a professional installer be consulted. Communitymailboxes assumes no product assembly or installation liability

# Mail Houses – 4750

## Bolt Mounted Post Installation Instructions

### Installing the Bolt Mounted Post onto Anchor Bolts

Dig the hole for the concrete footing, and prepare the concrete. You will need approximately 4-1/2 cubic feet. The top surface of the footing should be about 12" by 18" and extend 36" into the ground. See the illustration for the relative position of the rectangular footing to the post and mailbox. The bottom of the hole for the concrete footing should be filled with about 6" of gravel to promote drainage under the post. The top of the footing should be sloped for water runoff.

The concrete must be below the frost line. Otherwise the post will move when the ground freezes. Be careful not to puncture water, sewer, or gas lines when digging holes for footing.

Attach the 4 J-shaped anchor bolts to the base of the post with 4 nuts under and 4 nuts over the bottom mounting plate. Pour the concrete into the hole, prodding the mix with a stick while filling to reduce any air pockets. Press the anchor bolts on the bottom of the post into the concrete until the bottom plate is resting on the top surface of the wet concrete. Use a carpenter's level on the sides of the post to ensure that the post is aligned vertically. Periodically check the vertical alignment of the post as the concrete is curing.

The concrete will shrink as it hardens, leaving a space between the anchor and the concrete when it is cured. To prevent this, loosen the top bolt one full turn prior to inserting into the wet concrete. After the anchor is inserted into the wet concrete, place your foot on the top of the threaded anchor and push down until the top nut is pressed against the anchor plate. After the concrete has hardened, re-tighten the top bolt.

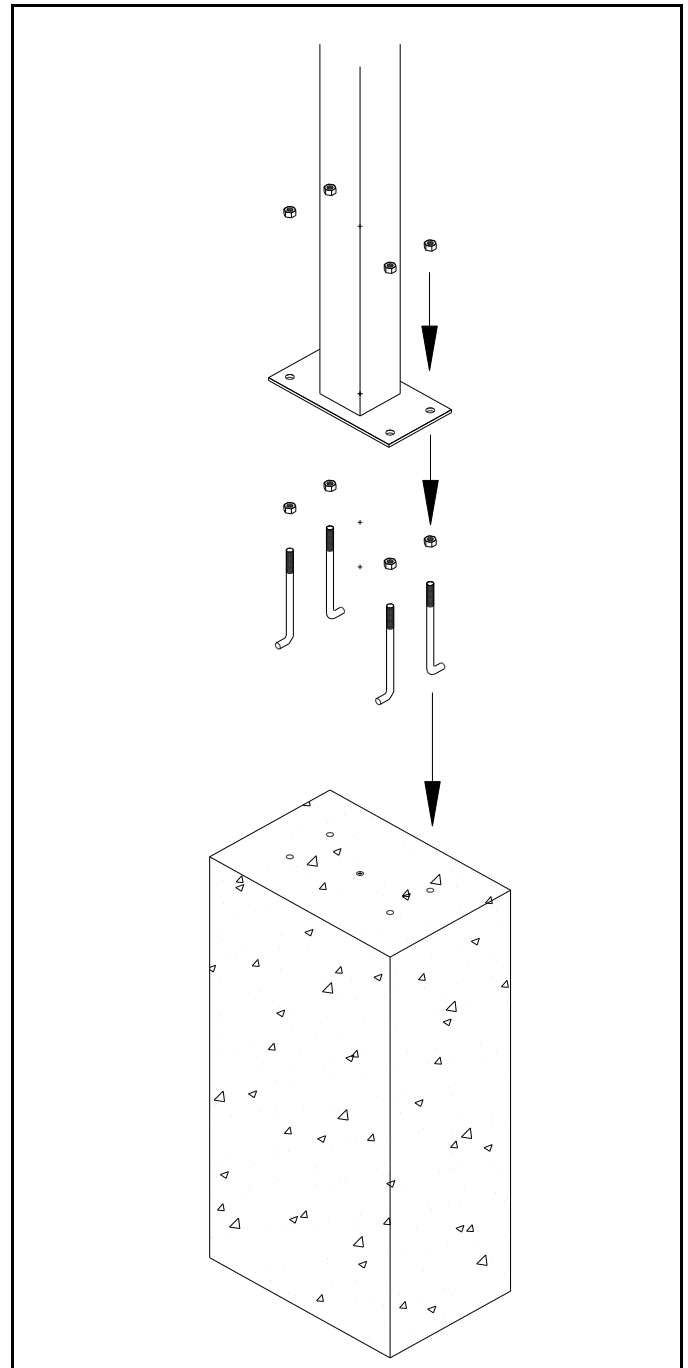

[www.Communitymailboxes.com](http://www.Communitymailboxes.com)

Phone: 1 888 863 1040 Fax: 1 707 265 0206

Installation instructions are provided as general guidelines. It is advised that a professional installer be consulted. Communitymailboxes assumes no product assembly or installation liability.