

# Fashion Bed Group

A Division of Leggett & Platt Incorporated  
5950 West 51st Street - Chicago, IL 60638

## Part List For Weston

### BED CARTONS

#### GRILL BOX

(5) GRILL (2)

PART #326901 HARDWARE BAG FOR BED GRILLS ASSEMBLY

- (1) 6mm X 90mm FLAT ALLEN HEAD SCREW-12  
(4) ALLEN WRENCH

#### POSTS BOX

(6) HEADBOARD POSTS(2)  
(7) FOOTBOARD POST(2)

PART #326902 HARDWARE BAG FOR BED FRAME ATTACHMENT

- (1) 6mm X 90mm FLAT ALLEN HEAD SCREW-8  
(2) 6mm HEX NUT-8  
(3) 5/8" OD METAL WASHER-16  
(4) ALLEN WRENCH

### HEADBOARD CARTONS

#### GRILL BOX

(5) GRILL (1)

PART #326903 HARDWARE BAG FOR HB GRILLS ASSEMBLY

- (1) 6mm X 90mm FLAT ALLEN HEAD SCREW-6  
(4) ALLEN WRENCH

#### POSTS BOX

(6) HEADBOARD POSTS(2)

PART #326904 HARDWARE BAG FOR BED FRAME ATTACHMENT

- (1) 6mm X 90mm FLAT ALLEN HEAD SCREW-4  
(2) 6mm HEX NUT-4  
(3) 5/8" OD METAL WASHER-8  
(4) ALLEN WRENCH

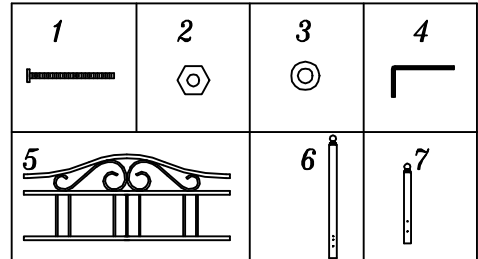

## PRODUCT FULLY ASSEMBLED

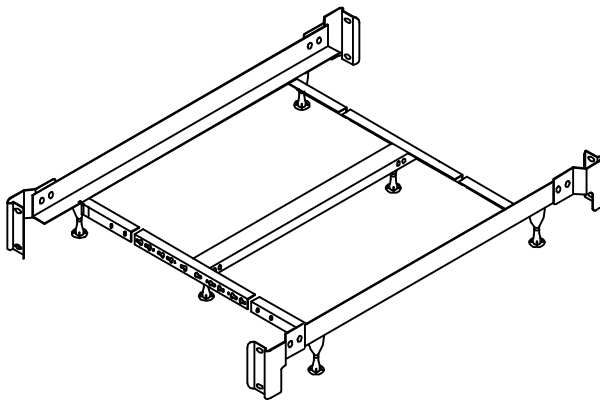
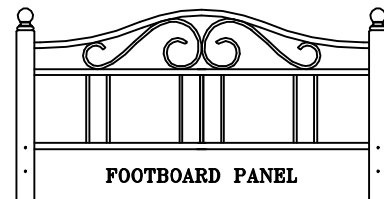
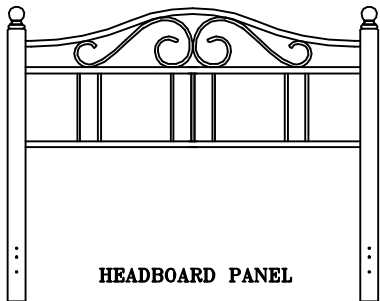

#### QUEEN - KING FRAME FULLY ASSEMBLED FRAMES

NOTE: SEE INSTRUCTIONS INCLUDED IN FRAME CARTON FOR FRAME ASSEMBLY

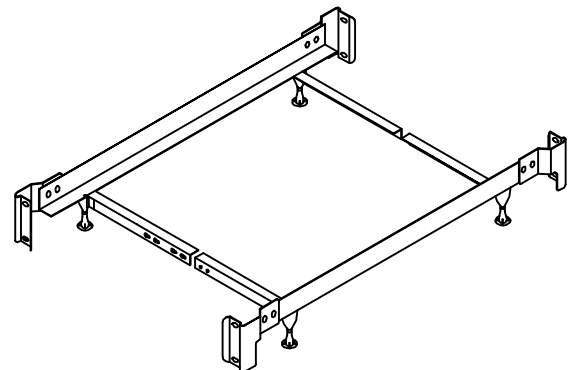

#### TWIN - FULL FRAME FULLY ASSEMBLED

NOTE: SEE INSTRUCTIONS INCLUDED IN FRAME CARTON FOR FRAME ASSEMBLY

FOR ASSISTANCE IN ASSEMBLY ONLY OF THIS PRODUCT, CALL OUR HELP DESK AT 1-800-324-3415, BETWEEN 8:30 AM & 4:30 PM CENTRAL TIME MONDAY THRU FRIDAY. PLEASE HAVE THE STYLE NUMBER AVAILABLE BEFORE YOU CALL. (STYLE # OR NAME CAN BE FOUND ON PACKING CARTON OR SALES RECEIPT.) OUR PRODUCT IS INSPECTED TO ENSURE IT IS IN GOOD CONDITION. IF YOUR FURNITURE APPEARS TO HAVE BEEN DAMAGED IN SHIPMENT OR YOU ARE IN NEED OF REPLACEMENT PARTS PLEASE CONTACT THE DEALER FROM WHOM YOU PURCHASED THE PRODUCT.

# Instruction Sheet

SAVE ALL PACKAGING MATERIALS UNTIL PRODUCT IS FULLY ASSEMBLED. HARDWARE AND SMALL PIECES MAY NOT BE SEEN AND BE ACCIDENTALLY DISCARDED WITH PACKAGING MATERIALS.

FIGURE 1

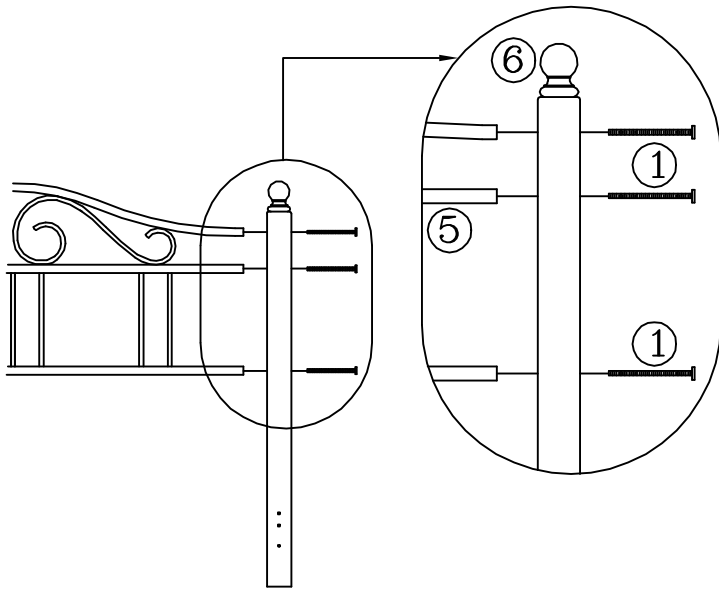

FIGURE 2

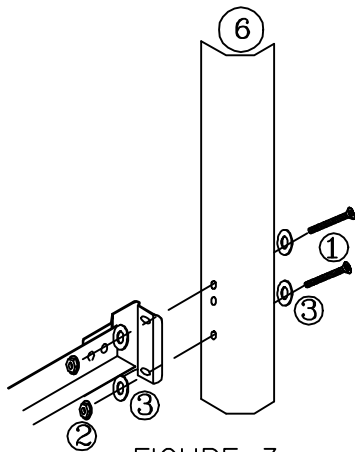
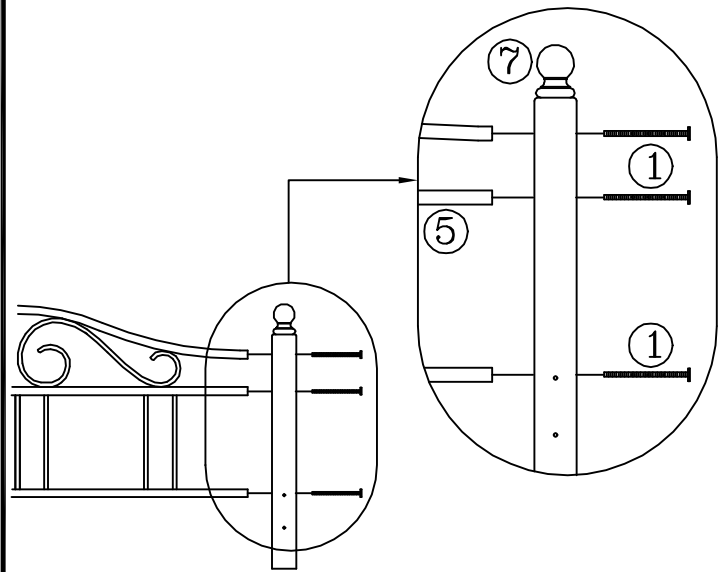

FIGURE 3

### Step 1

- Align grill (5) rail ends with holes in headboard post (6). See Figure 1
- Secure post (6) to grill (5) with screws (1). See Figure 1
- Repeat on other side of headboard panel.
- Tighten all screws securely using the Allen wrench.
- Repeat same step for assembly of footboard. (See Figure 2)

### Step 2

- Place headboard and frame in desire location in room.
- Place 2 screws (1) with washers (3) through holes located in post (6). (See Figure 3)
- Align bed frame bracket over screws.
- Place a washer (3) first and then a nut (2) on each screw. Hand-tighten, DO NOT TIGHTEN screws all the way.
- Repeat on other side of headboard.
- Tighten all screws securely using the Allen wrench.

### Step 3

- Position footboard panel and align holes in the post (7) with holes in the frame bracket. See Figure 4
- Insert 2 screws (1) with washers (3) through holes located in post (7) into frame bracket holes. (See Figure 4)
- Place a washer (3) first and then a nut (2) on each screw. Hand-tighten, DO NOT TIGHTEN screws all the way.
- Repeat on other side of footboard panel.
- Tighten all screws securely using the Allen wrench.

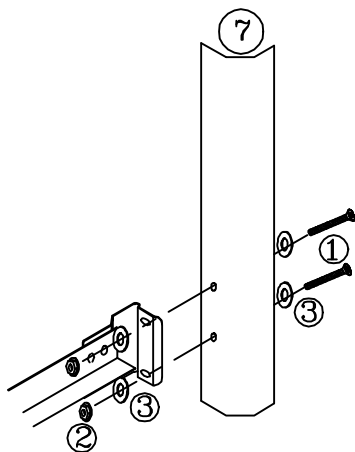

FIGURE 4

# Fashion Bed Group

A Division of Leggett & Platt Incorporated  
5950 West 51st Street - Chicago, IL 60638

## Part List For Weston Twin Bed

### BED CARTON

PART #328201 HARDWARE BAG FOR BED ASSEMBLY

- (1) 6mm X 90mm SOCKET ALLEN HEAD SCREW-16
- (2) 6mm X 20mm SOCKET ALLEN HEAD SCREW-4
- (3) METAL WASHER-12
- (4) 6mm HEX NUTS-4
- (5) ALLEN WRENCH
- (6) GRILL-2
- (7) HEADBOARD POSTS-2
- (8) FOOTBOARD POST-2

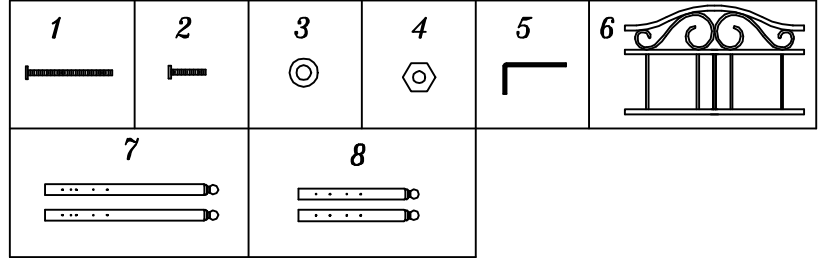

### PRODUCT FULLY ASSEMBLED

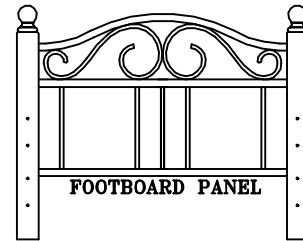
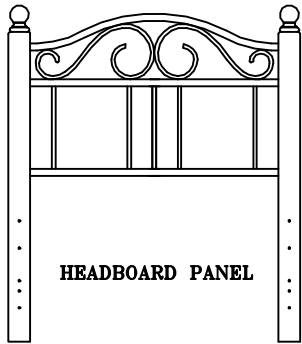

### Twin Size Options

- 1st. USE LINK SPRING (UPPER CONNECTION) FOR TRUNDLE APPLICATION (ONLY A MATTRESS).
- 2nd. USE FRAME (LOWER CONNECTION) W/BOX SPRING AND MATTRESS.

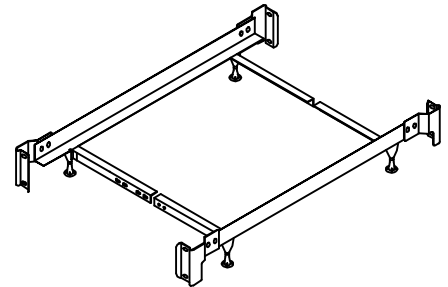
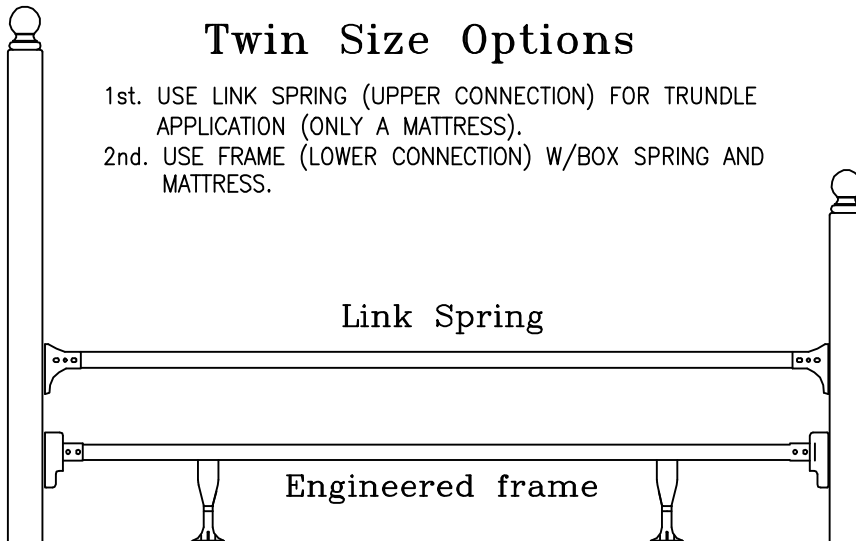

TWIN - FULL FRAME FULLY ASSEMBLED  
NOTE: SEE INSTRUCTIONS INCLUDED IN FRAME CARTON FOR FRAME ASSEMBLY

#### OPTIONAL

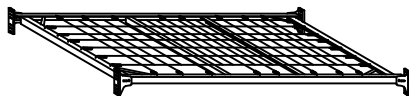

MATTRESS LINK SPRING FULLY ASSEMBLED

#### OPTIONAL

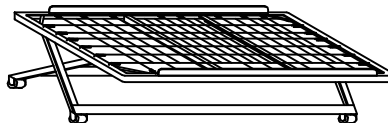

POP-UP TRUNDLE

FOR ASSISTANCE IN ASSEMBLY ONLY OF THIS PRODUCT, CALL OUR HELP DESK AT 1-800-324-3415, BETWEEN 8:30 AM & 4:30 PM CENTRAL TIME MONDAY THRU FRIDAY. PLEASE HAVE THE STYLE NUMBER AVAILABLE BEFORE YOU CALL. (STYLE # OR NAME CAN BE FOUND ON PACKING CARTON OR SALES RECEIPT.) OUR PRODUCT IS INSPECTED TO ENSURE IT IS IN GOOD CONDITION. IF YOUR FURNITURE APPEARS TO HAVE BEEN DAMAGED IN SHIPMENT OR YOU ARE IN NEED OF REPLACEMENT PARTS PLEASE CONTACT THE DEALER FROM WHOM YOU PURCHASED THE PRODUCT.

# Instruction Sheet

SAVE ALL PACKAGING MATERIALS UNTIL PRODUCT IS FULLY ASSEMBLED. HARDWARE AND SMALL PIECES MAY NOT BE SEEN AND BE ACCIDENTALLY DISCARDED WITH PACKAGING MATERIALS.

FIGURE 1

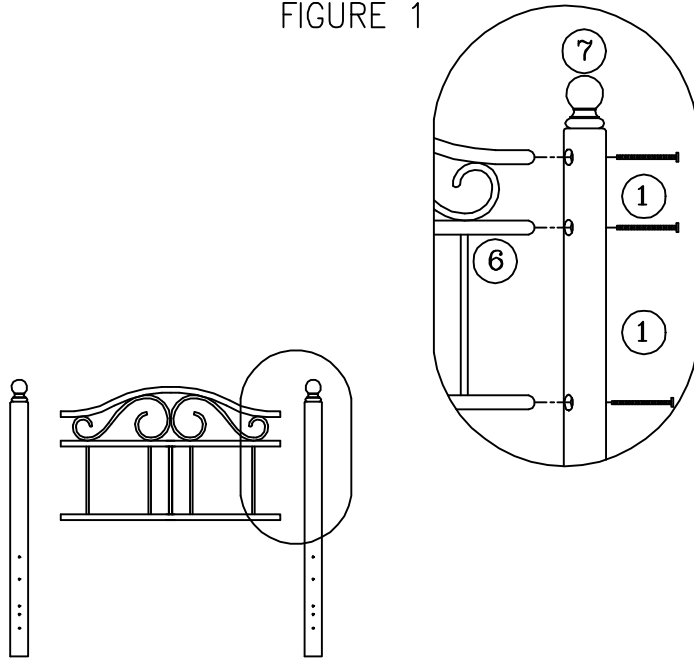

FIGURE 2

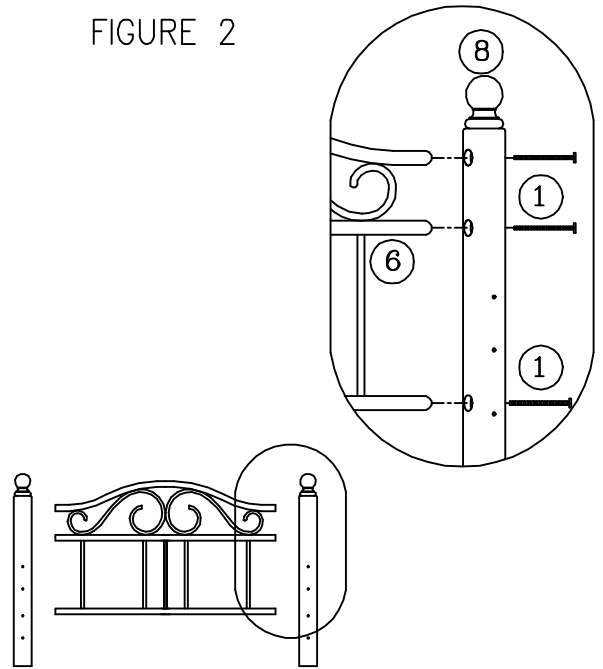
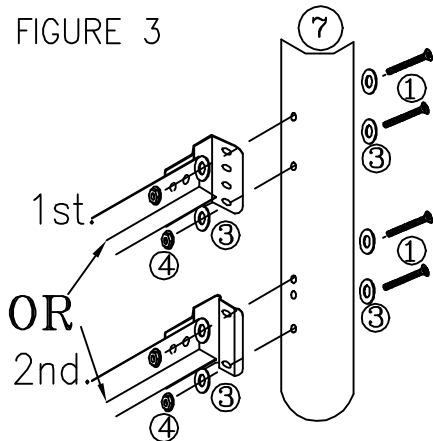

FIGURE 3



## Step 1

- Align grill (6) rail ends with larger recessed holes in the upper portion of the headboard post (7). See Figure 1
- Secure post (7) to grill (6) with screws (1). See Figure 1
- Repeat on other side of headboard panel.
- Tighten all screws securely using the Allen wrench.
- Repeat same step for the assembly of footboard. See Figure 2

## Step 2

Note: YOU HAVE TWO ASSEMBLY OPTIONS WITH A TWIN SIZE:  
1st. USE UPPER ASSEMBLY IF USING AS A TRUNDLE UNIT WITH MATTRESS ONLY.

2nd. USE LOWER FRAME ASSEMBLY IF USING BOX SPRING & MATTRESS.

- Place headboard and frame in desire location in room.
- Place 2 screws (1) with washers (3) through holes located in post (7). (See Figure 3)
- Align bed frame bracket over screws.
- Place a washer (3) first and then a nut (4) on each screw. Hand-tighten, DO NOT TIGHTEN screws all the way.
- Repeat on other side of headboard.
- Tighten all screws securely using the Allen wrench.

FIGURE 4

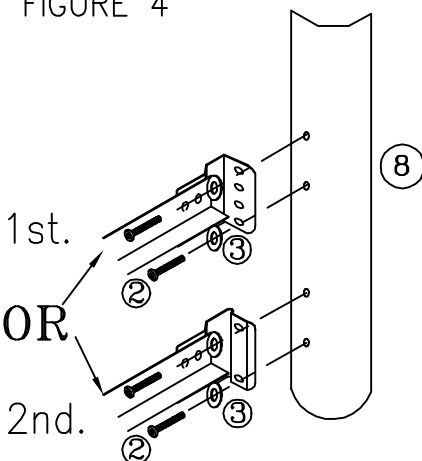

## Step 3

- Position footboard panel and align holes in the post (8) with holes in the frame bracket. See figure 4
- Note: Use the same hole position that you used for the headboard attachment of to the frame or link spring.
- Place washer (3) on each screw (2). Insert through bracket into post.
- Hand-tighten, DO NOT TIGHTEN screws all the way.
- Repeat on other side of footboard panel.
- Tighten all screws securely using the Allen wrench.

# Fashion Bed Group

A Division of Leggett & Platt Incorporated  
5950 West 51st Street - Chicago, IL 60638

## Part List For Weston Twin Headboard

### HEADBOARD CARTON

PART #328301 HARDWARE BAG FOR HEADBOARD ASSEMBLY

- (1) 6mm X 90mm SOCKET ALLEN HEAD SCREW-8
- (2) METAL WASHER-8
- (3) 6mm HEX NUTS-4
- (4) ALLEN WRENCH
- (5) GRILL-1
- (6) HEADBOARD POSTS-2

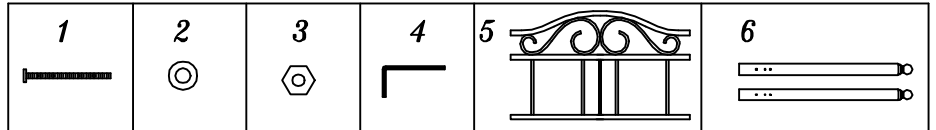

### PRODUCT FULLY ASSEMBLED

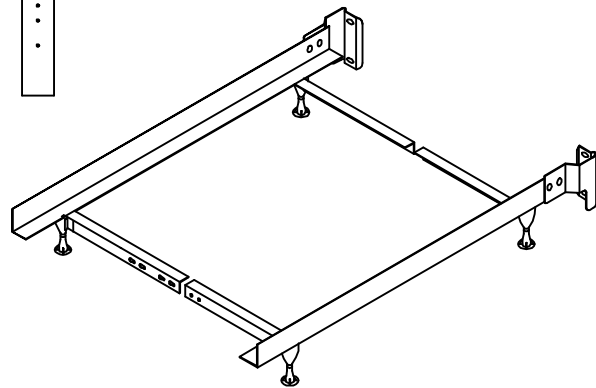
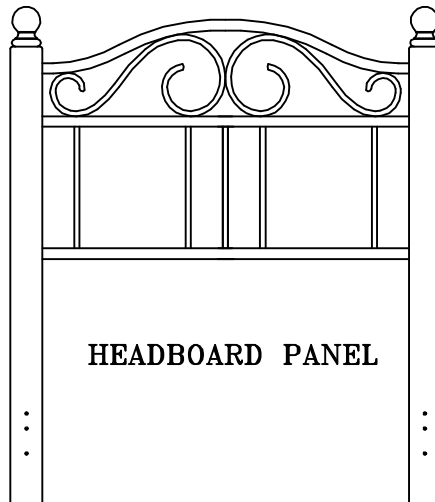

**TWIN - FULL FRAME FULLY ASSEMBLED**

**NOTE: SEE INSTRUCTIONS INCLUDED IN FRAME CARTON FOR FRAME ASSEMBLY**

FOR ASSISTANCE IN ASSEMBLY ONLY OF THIS PRODUCT, CALL OUR HELP DESK AT 1-800-324-3415, BETWEEN 8:30 AM & 4:30 PM CENTRAL TIME MONDAY THRU FRIDAY. PLEASE HAVE THE STYLE NUMBER AVAILABLE BEFORE YOU CALL. (STYLE # OR NAME CAN BE FOUND ON PACKING CARTON OR SALES RECEIPT.) OUR PRODUCT IS INSPECTED TO ENSURE IT IS IN GOOD CONDITION. IF YOUR FURNITURE APPEARS TO HAVE BEEN DAMAGED IN SHIPMENT OR YOU ARE IN NEED OF REPLACEMENT PARTS PLEASE CONTACT THE DEALER FROM WHOM YOU PURCHASED THE PRODUCT.

# Instruction Sheet

SAVE ALL PACKAGING MATERIALS UNTIL PRODUCT IS FULLY ASSEMBLED. HARDWARE AND SMALL PIECES MAY NOT BE SEEN AND BE ACCIDENTALLY DISCARDED WITH PACKAGING MATERIALS.

FIGURE 1

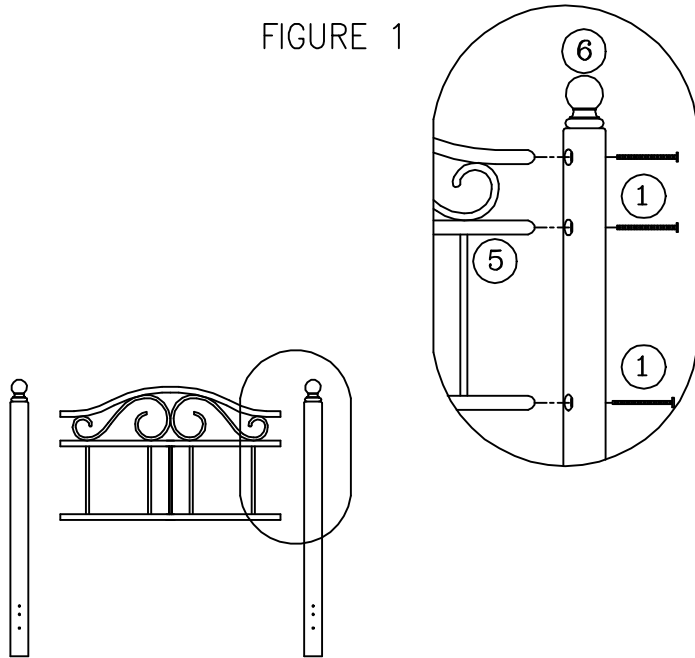
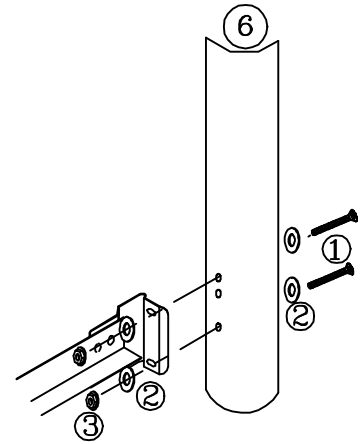

FIGURE 2



## Step 1

- Align grill (5) rail ends with larger recessed holes in the upper portion of the headboard post (6). See Figure 1
- Secure post (6) to grill (5) with screws (1). See Figure 1
- Repeat on other side of headboard panel.
- Tighten all screws securely using the Allen wrench.

## Step 2

- Place headboard and frame in desire location in room.
- Place 2 screws (1) with washers (2) through holes located in post (6). (See Figure 2)
- Align bed frame bracket over screws.
- Place a washer (2) first and then a nut (3) on each screw. Hand-tighten, DO NOT TIGHTEN screws all the way.
- Repeat on other side of headboard.
- Tighten all screws securely using the Allen wrench.