

Fashion Bed Group

A Division of Leggett & Platt Incorporated
5950 West 51st Street - Chicago, IL 60638

Parts List For Sycamore bed

BED CARTON

- (7) HEADBOARD PANEL
- (8) FOOTBOARD PANEL

HARDWARE BAG FOR BED ATTACHMENT TO FRAME

- (1) 6mm X 55mm FLAT ALLEN HEAD SCREW-8
- (2) 6mm HEX NUT-8
- (3) 6.5mm FLAT STEEL WASHER-8
- (4) ALLEN WRENCH-1
- (5) LEG EXTENSION-2
- (6) FINIAL-4

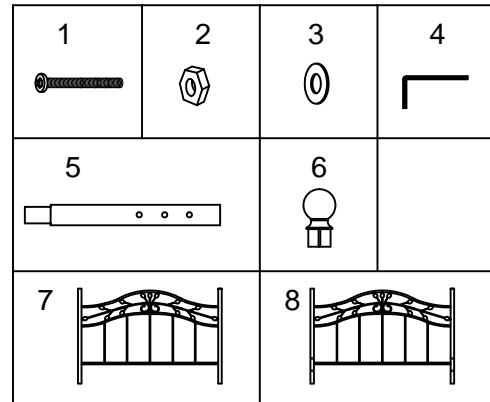

PRODUCT FULLY ASSEMBLED

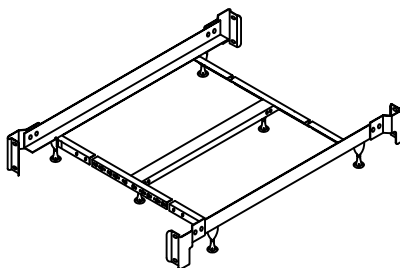
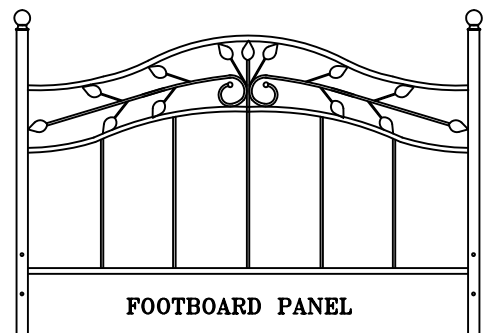
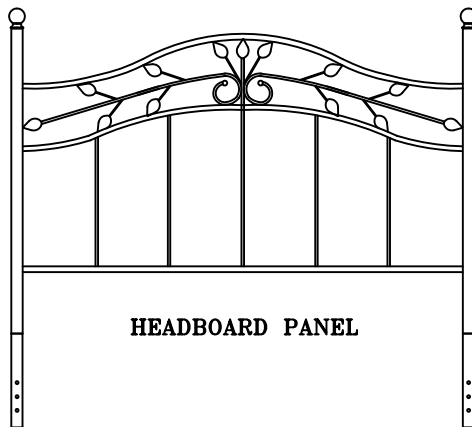

QUEEN - KING BED FRAME FULLY ASSEMBLED
NOTE: SEE INSTRUCTIONS INCLUDED IN FRAME CARTON FOR FRAME ASSEMBLY

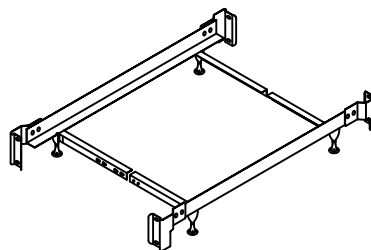

TWIN - FULL BED FRAME FULLY ASSEMBLED
NOTE: SEE INSTRUCTIONS INCLUDED IN FRAME CARTON FOR FRAME ASSEMBLY

FOR ASSISTANCE IN ASSEMBLY ONLY OF THIS PRODUCT. CALL OUR HELP DESK AT 1-800-324-3415, BETWEEN 8:30 AM & 4:30 PM CENTRAL TIME MONDAY THRU FRIDAY. PLEASE HAVE THE STYLE NUMBER AVAILABLE BEFORE YOU CALL. (STYLE # OR NAME CAN BE FOUND ON PACKING CARTON OR SALES RECEIPT.) OUR PRODUCT IS INSPECTED TO ENSURE IT IS IN GOOD CONDITION. IF YOUR FURNITURE APPEARS TO HAVE BEEN DAMAGED IN SHIPMENT OR YOU ARE IN NEED OF REPLACEMENT PARTS PLEASE CONTACT THE DEALER FROM WHOM YOU PURCHASED THE PRODUCT.

Instruction Sheet

SAVE ALL PACKAGING MATERIALS UNTIL PRODUCT IS FULLY ASSEMBLED. HARDWARE AND SMALL PIECES MAY NOT BE SEEN AND BE ACCIDENTALLY DISCARDED WITH PACKAGING MATERIALS.

FIGURE 1

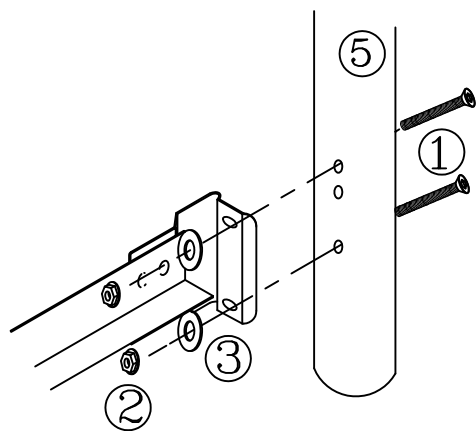
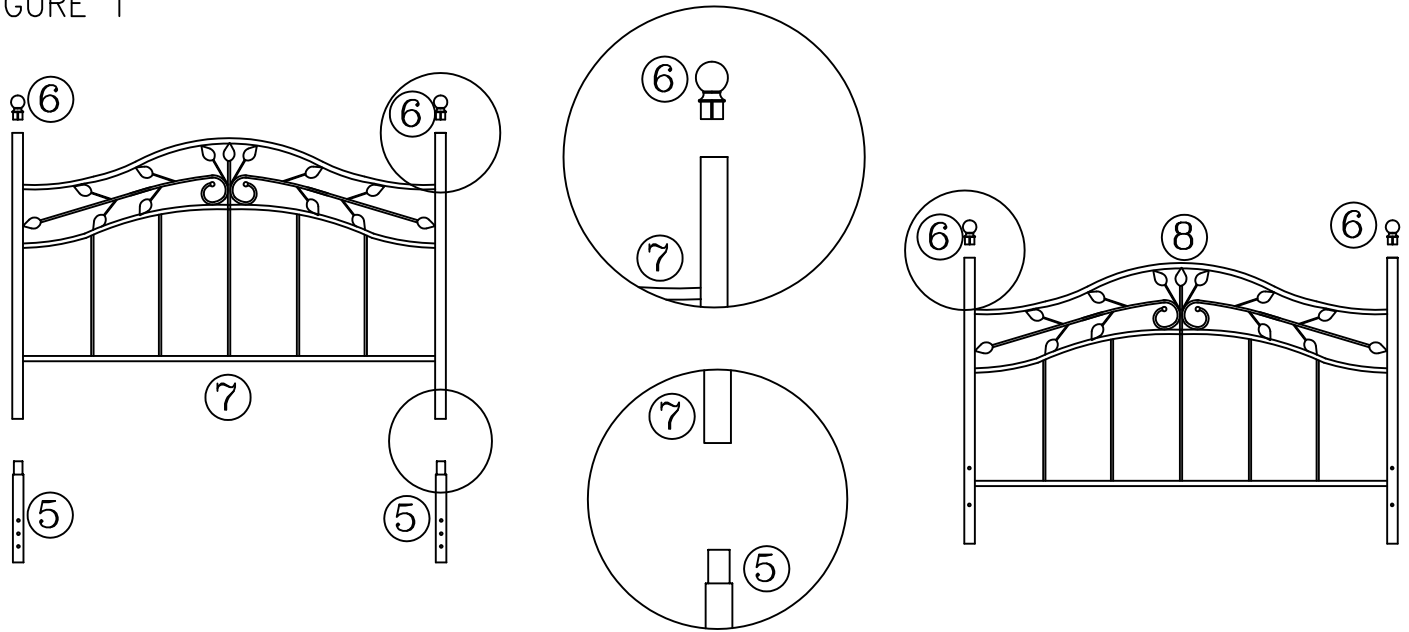

FIGURE 2

Step 1

- Align top reduction of extension legs (5) with bottom of headboard posts. (See Figure 1) Make sure the 3 holes on extension legs are perpendicular to headboard panel.
- Now carefully insert extension legs (5) into bottom of headboard (7) posts.
- Push in finials (6) on top of headboard (7) and footboard (8) posts. (See Figure 1)

Step 2

- Place headboard and frame in desired location in room.
- Place 2 screws (1) through holes located in leg (5). (See Figure 2)
- Align bed frame bracket over screws.
- Place a flat washer (3) first, and a nut (2) on each screw. Hand-tighten, DO NOT TIGHTEN screws all the way.
- Repeat on other side of headboard.
- Tighten all screws securely using the Allen wrench (4).

Step 3

- Position footboard panel (8) and align holes in the post with holes in the frame bracket. (See figure 3)
- Place 2 screws (1) through holes located in footboard (8) post.
- Align bed frame bracket over screws.
- Place a flat washer (3) first, and a nut (2) on each screw. Hand-tighten, DO NOT TIGHTEN screws all the way.
- Repeat on other side of headboard.
- Tighten all screws securely using the Allen wrench (4).

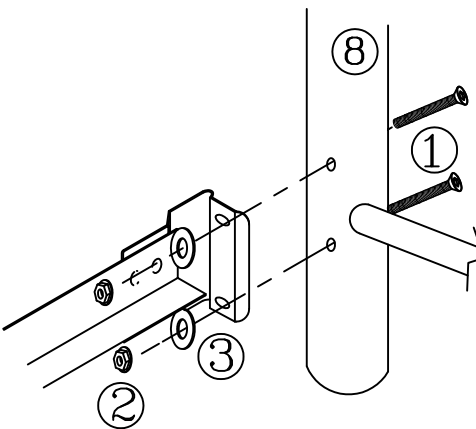

FIGURE 3

Fashion Bed Group

A Division of Leggett & Platt Incorporated
5950 West 51st Street - Chicago, IL 60638

Sycamore Duo Parts List

DUO CARTON

- (7) GRILL-1
- (8) LEG EXTENSION-2
- (9) DUO POST-2
- (10) FINIAL-2

HARDWARE BAG FOR DUO ASSEMBLY

- (1) 6mm X 55mm COUNTER SUNK ALLEN HEAD SCREW-10
- (2) 6mm HEX NUT-4
- (3) 6.5mm OD FLAT WASHER-4
- (4) 3/4" OD METAL CAP-6
- (5) ALLEN WRENCH-1
- (6) PLASTIC GLIDE-2

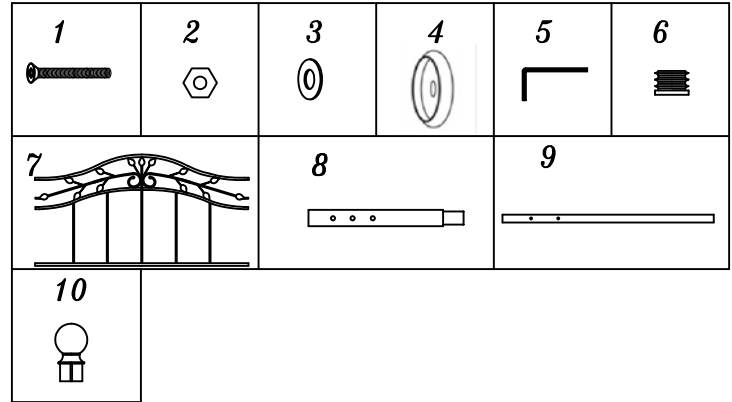

PRODUCT FULLY ASSEMBLED

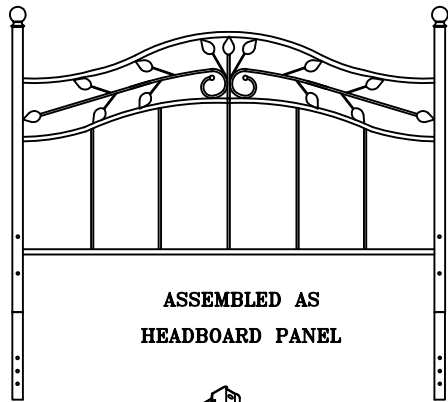

ASSEMBLED AS
HEADBOARD PANEL

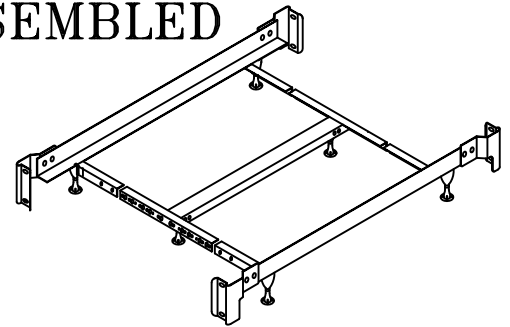

QUEEN - KING BED FRAME FULLY ASSEMBLED

NOTE: SEE INSTRUCTIONS INCLUDED IN FRAME CARTON FOR FRAME ASSEMBLY

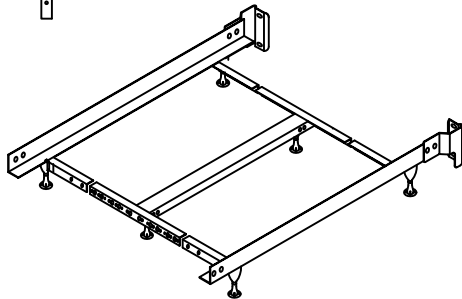

QUEEN - KING HEADBOARD ONLY FRAME FULLY ASSEMBLED FRAMES

NOTE: SEE INSTRUCTIONS INCLUDED IN FRAME CARTON FOR FRAME ASSEMBLY

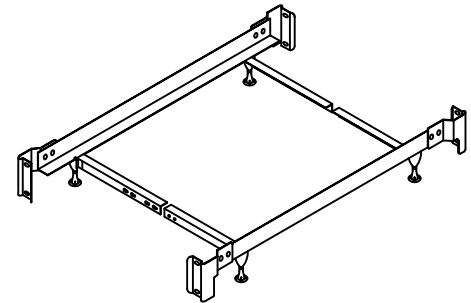

TWIN - FULL BED FRAME FULLY ASSEMBLED

NOTE: SEE INSTRUCTIONS INCLUDED IN FRAME CARTON FOR FRAME ASSEMBLY

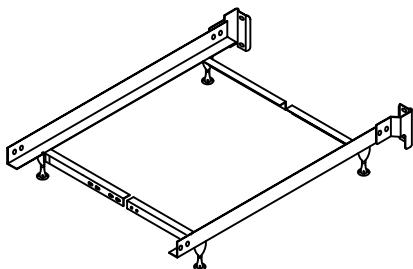

TWIN - FULL HEADBOARD ONLY FRAME FULLY ASSEMBLED

NOTE: SEE INSTRUCTIONS INCLUDED IN FRAME CARTON FOR FRAME ASSEMBLY

FOR ASSISTANCE IN ASSEMBLY ONLY OF THIS PRODUCT. CALL OUR HELP DESK AT 1-800-324-3415, BETWEEN 8:30 AM & 4:30 PM CENTRAL TIME MONDAY THRU FRIDAY. PLEASE HAVE THE STYLE NUMBER AVAILABLE BEFORE YOU CALL. (STYLE # OR NAME CAN BE FOUND ON PACKING CARTON OR SALES RECEIPT.) OUR PRODUCT IS INSPECTED TO ENSURE IT IS IN GOOD CONDITION. IF YOUR FURNITURE APPEARS TO HAVE BEEN DAMAGED IN SHIPMENT OR YOU ARE IN NEED OF REPLACEMENT PARTS PLEASE CONTACT THE DEALER FROM WHOM YOU PURCHASED THE PRODUCT.

Instruction Sheet

SAVE ALL PACKAGING MATERIALS UNTIL PRODUCT IS FULLY ASSEMBLED. HARDWARE AND SMALL PIECES MAY NOT BE SEEN AND BE ACCIDENTALLY DISCARDED WITH PACKAGING MATERIALS.

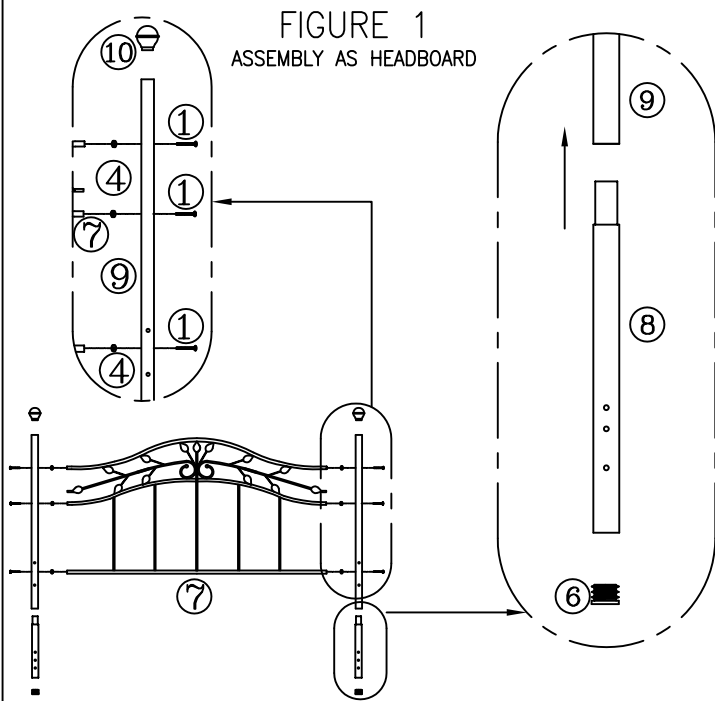

FIGURE 1
ASSEMBLY AS HEADBOARD

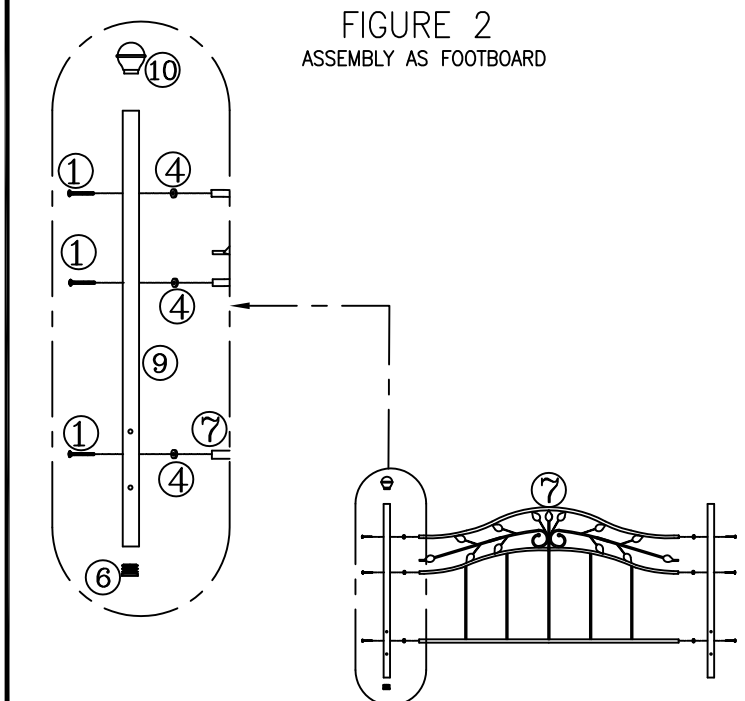

FIGURE 2
ASSEMBLY AS FOOTBOARD

NOTE: This product can be used as Headboard or as Footboard

For Headboard assembly

- Align grill (7) rail ends with holes in post (9). See Figure 1
- Secure post (9) to grill (7) with screws (1) and metal caps (4). See Figure 1
- Repeat on other side of panel.
- Tighten all screws securely using the Allen wrench.
- Align top reduction of extension legs (8) with bottom of headboard posts. (See Figure 1) Make sure the 3 holes on extension legs are perpendicular to headboard panel.
- Now carefully insert extension legs (8) into bottom of panel posts (9).
- Insert plastic glides (6) into legs (8). See Figure 1
- Push in finials (10) on top of posts (9).

For Footboard assembly

- Discard leg extensions (8) for footboard attachment to frame.
- Align grill (7) rail ends with holes in post (9). See Figure 1
- Secure post (9) to grill (7) with screws (1) and metal caps (4). See Figure 1
- Repeat on other side of panel.
- Tighten all screws securely using the Allen wrench.
- Insert plastic glides (6) into post (9). See Figure 1

Headboard attachment to frame

- Place headboard and frame in desired location in room.
- Place 2 screws (1) through holes located in leg (8). (See Figure 3)
- Align bed frame bracket over screws.
- Place a flat washer (3) first and then a nut (2) on each screw. Hand-tighten, DO NOT TIGHTEN screws all the way.
- Repeat on other side of headboard.
- Tighten all screws securely using the Allen wrench (5).

Footboard attachment to Frame

- Place 2 screws (1) through holes located in post (9). (See Figure 4)
- Align bed frame bracket over screws.
- Place a flat washer (3) first and then a nut (2) on each screw. Hand-tighten, DO NOT TIGHTEN screws all the way.
- Repeat on other side of footboard.
- Tighten all screws securely using the Allen wrench (5).

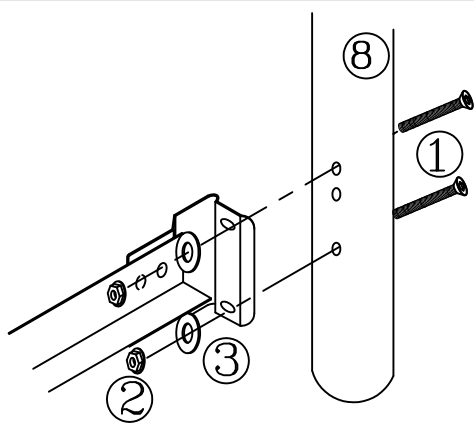

FIGURE 3

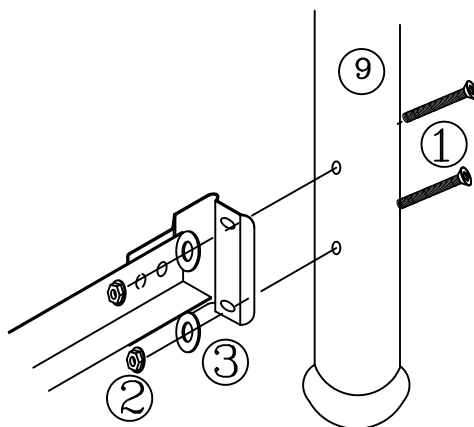

FIGURE 4