

# Fashion Bed Group

A Division of Leggett & Platt Incorporated  
5950 West 51st Street - Chicago, IL 60638

## Parts List For Stratford Daybed

### PART #361101 HARDWARE BAG FOR DAYBED

- (1) 6mm x 1" FLAT ALLEN HEAD SCREW-8
- (2) 6mm x 1 1/2" FLAT ALLEN HEAD SCREW-4
- (3) 1/4" ID METAL WASHER-12
- (4) 1/4" ID PVC WASHER-8
- (5) ALLEN WRENCH-1

#### DAYBED PARTS:

- (6) LEFT SIDE-1
- (7) RIGHT SIDE-1
- (8) BACK PANEL-1

#### LINK SPRING PARTS:

- (9) LEFT BRACKET-2
- (10) RIGHT BRACKET-2
- (11) 5/16-18 SCREW-4
- (12) 5/16-18 HEX NUT-4
- (13) SUPPORT DECK-1

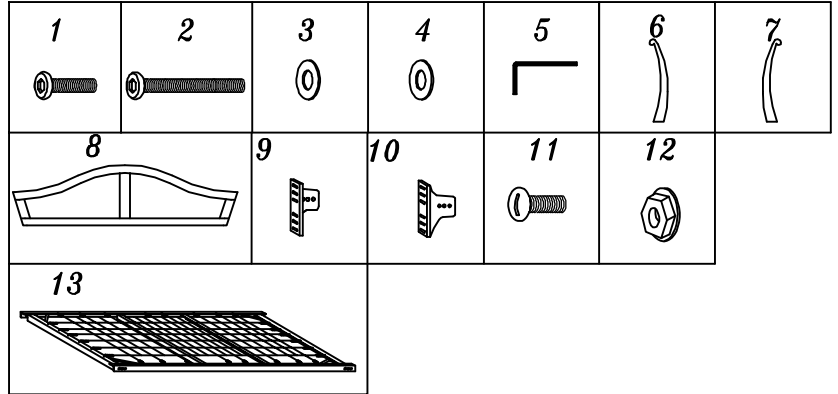

SAVE ALL PACKAGING MATERIALS UNTIL PRODUCT IS FULLY ASSEMBLED. HARDWARE AND SMALL PIECES MAY NOT BE SEEN AND BE ACCIDENTALLY DISCARDED WITH PACKAGING MATERIALS.

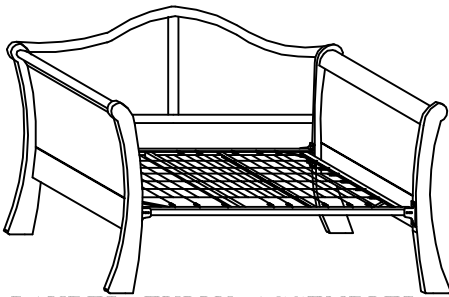

DAYBED FULLY ASSEMBLED

MATTRESS LINK SPRING FULLY ASSEMBLED

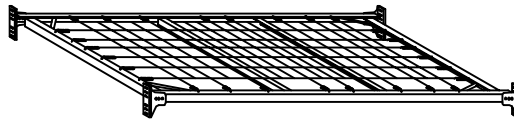

OPTIONAL

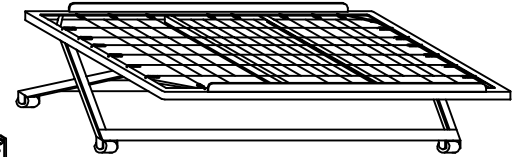

POP-UP TRUNDLE

## Instruction Sheet

- NOTES:**
- For ease of assembly you will need a helper.
  - Loosely secure hardware, tighten after securing to daybed.

### Step 1- Locate Hardware bags for Daybed & Link Spring Assembly

- Hardware bag for assembly Daybed is located inside the daybed carton box.
- Link spring hardware bag is located below the link spring cross bar.

### Step 2- Link Spring Assembly

- loosely tighten left & right brackets (9 & 10) to side rails using screws (11) and nuts (12). See Figure 1

FIGURE 1

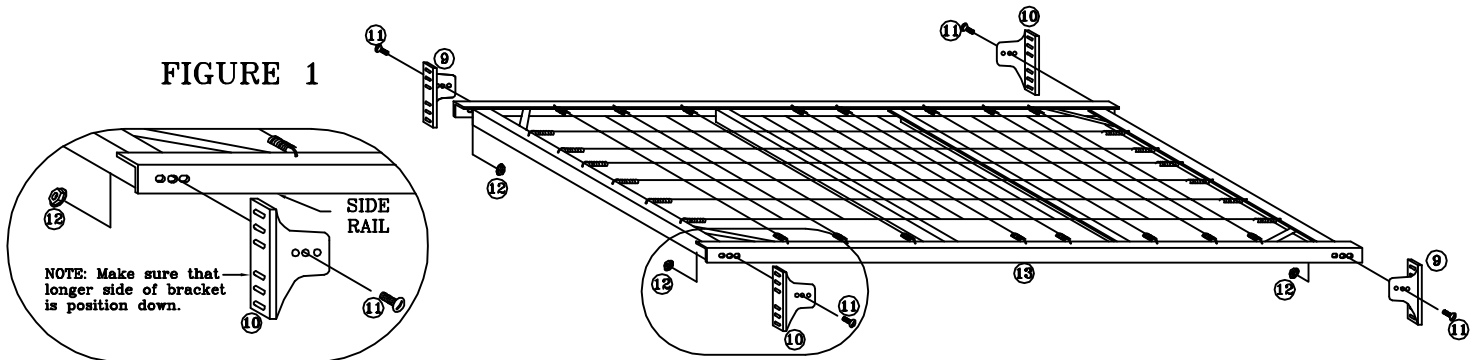

# Instruction Sheet

## Step 3- Attachment of Link Spring to Daybed sides

- Attach the metal bracket on the link spring to one daybed side post.
- For each post use 2 screws (1), 2 metal washers (3), 2 PVC washers (4).  
Loosely tighten (See Figure 2)
- Repeat on other daybed posts.

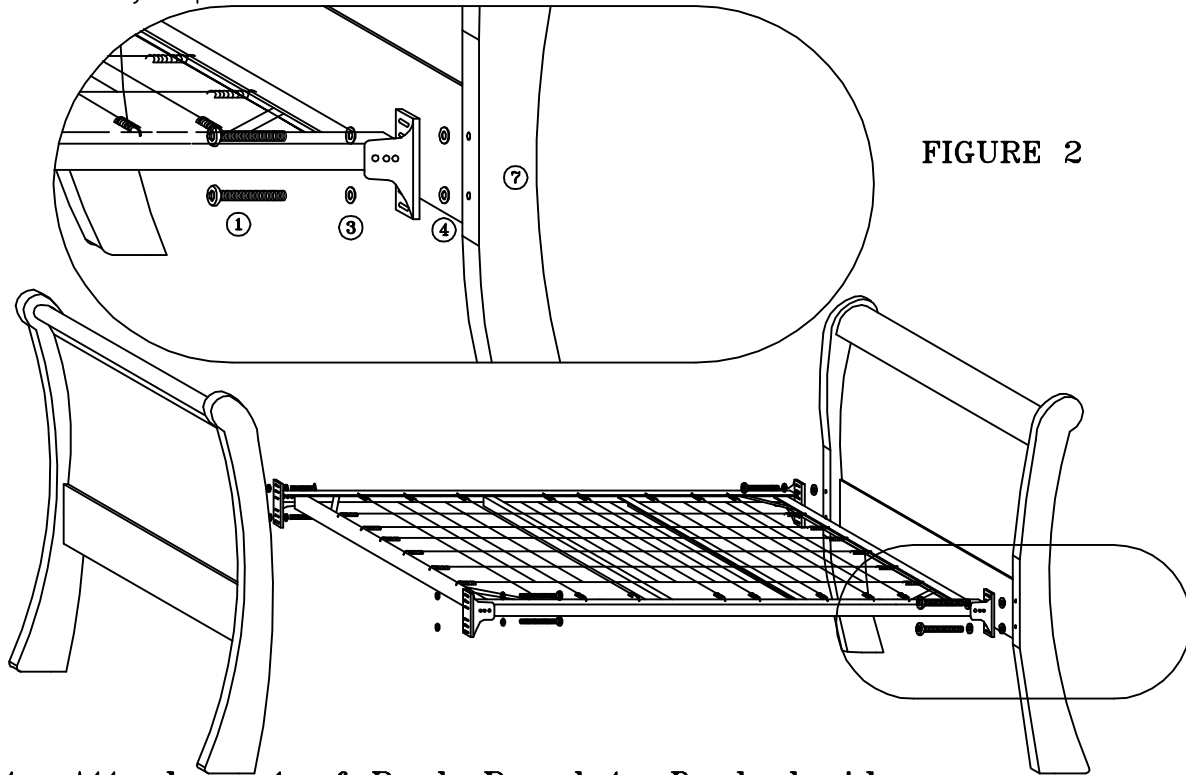

FIGURE 2

## Step 4- Attachment of Back Panel to Daybed sides

- Align rail ends of back panel (8) to holes in left side (6) back post.  
(See Figure 3)
- Secure panel to post by using screws (2) and metal washers (3). DO NOT TIGHTEN SCREWS.
- Repeat same step for assembly of right side (7) back post to back panel.  
(See Figure 3)
- Tighten all screws with Allen wrench (5).
- You are now ready for mattress installation.

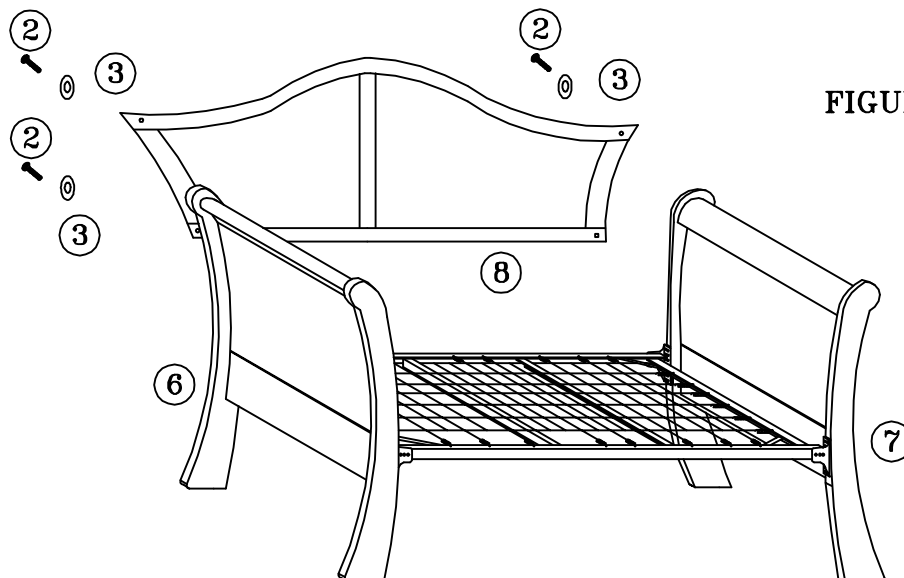
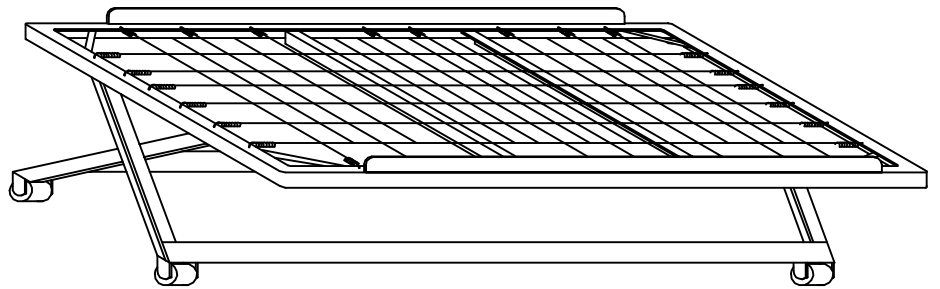
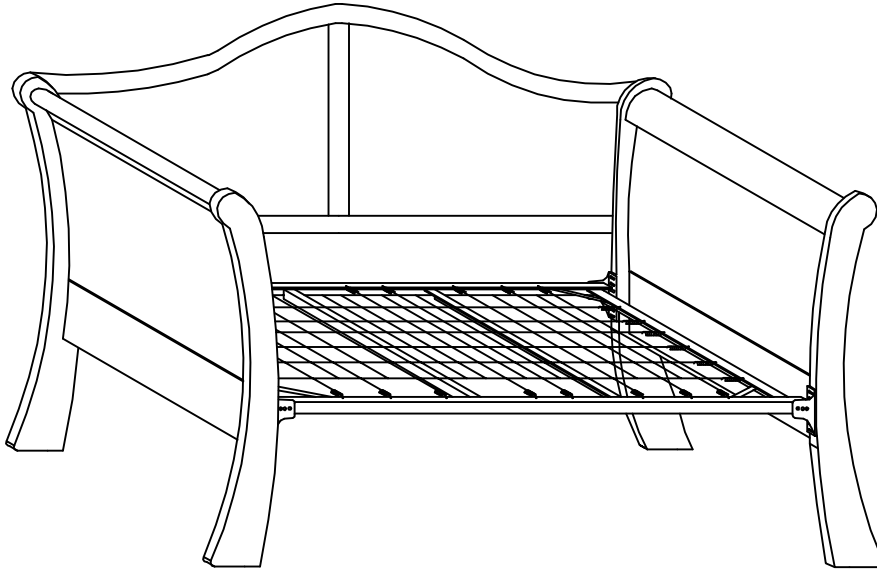

FIGURE 3

FOR ASSISTANCE IN ASSEMBLY ONLY OF THIS PRODUCT. CALL OUR HELP DESK AT 1-800-324-3415, BETWEEN 8:30 AM & 4:30 PM CENTRAL TIME MONDAY THRU FRIDAY. PLEASE HAVE THE STYLE NUMBER AVAILABLE BEFORE YOU CALL. (STYLE # OR NAME CAN BE FOUND ON PACKING CARTON OR SALES RECEIPT.) OUR PRODUCT IS INSPECTED TO ENSURE IT IS IN GOOD CONDITION. IF YOUR FURNITURE APPEARS TO HAVE BEEN DAMAGED IN SHIPMENT OR YOU ARE IN NEED OF REPLACEMENT PARTS PLEASE CONTACT THE DEALER FROM WHOM YOU PURCHASED THE PRODUCT.

# Instruction Sheet



OPTIONAL

**FIGURE 4**

FOR ASSISTANCE IN ASSEMBLY ONLY OF THIS PRODUCT. CALL OUR HELP DESK AT 1-800-324-3415, BETWEEN 8:30 AM & 4:30 PM CENTRAL TIME MONDAY THRU FRIDAY. PLEASE HAVE THE STYLE NUMBER AVAILABLE BEFORE YOU CALL. (STYLE # OR NAME CAN BE FOUND ON PACKING CARTON OR SALES RECEIPT.) OUR PRODUCT IS INSPECTED TO ENSURE IT IS IN GOOD CONDITION. IF YOUR FURNITURE APPEARS TO HAVE BEEN DAMAGED IN SHIPMENT OR YOU ARE IN NEED OF REPLACEMENT PARTS PLEASE CONTACT THE DEALER FROM WHOM YOU PURCHASED THE PRODUCT.