











Fashion Bed Group

A Division of Leggett & Platt Incorporated
5950 West 51st Street - Chicago, IL 60638

Parts List For Dexter

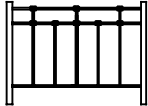
| BED CARTON | HEADBOARD CARTON | | | | |
|--|---|---|---|--|--|
| (10) HEADBOARD PANEL (11) FOOTBOARD PANEL | (10) HEADBOARD PANEL | 1  | 2  | 3  | 4  |
| PART #351501 HARDWARE BAG FOR BED ATTACHMENT TO FRAME | PART #351502 HARDWARE BAG FOR HEADBOARD ATTACHMENT TO FRAME | 5  | 6  | 7  | 8  |
| (1) 1/4-20 2 1/4" COUNTER SUNK ALLEN HEAD SCREW-4 (2) 1/4-20 1" FLAT ALLEN HEAD SCREW-4 (3) 1/4-20 HEX NUT-4 (4) 5/8" OD FLAT WASHER-8 (5) ALLEN WRENCH (6) PLASTIC GLIDE-4 | (1) 1/4-20 2 1/4" COUNTER SUNK ALLEN HEAD SCREW-4 (3) 1/4-20 HEX NUT-4 (4) 5/8" OD FLAT WASHER-4 (5) ALLEN WRENCH (6) PLASTIC GLIDE-2 | 9  | 10  | | |
| (7) FINIAL-4 (8) FOOT CASTING-2 (9) LEG EXTENSION-2 | (7) FINIAL-2 (9) LEG EXTENSION-2 | 11  | | | |

PRODUCT FULLY ASSEMBLED

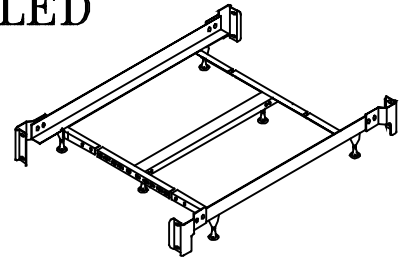
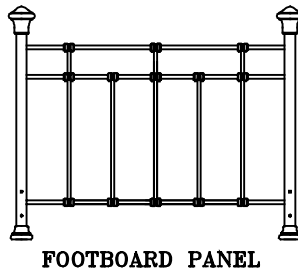
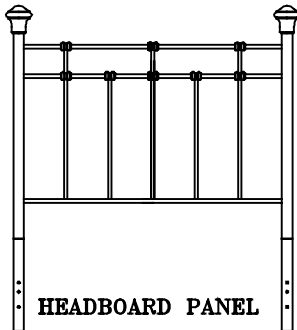

QUEEN - KING BED FRAME FULLY ASSEMBLED
NOTE: SEE INSTRUCTIONS INCLUDED IN FRAME CARTON FOR FRAME ASSEMBLY

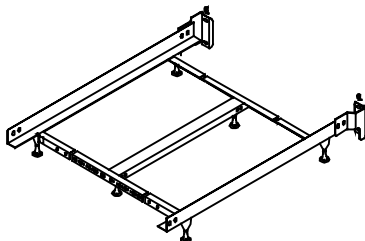

QUEEN - KING HEADBOARD ONLY FRAME FULLY ASSEMBLED FRAMES
NOTE: SEE INSTRUCTIONS INCLUDED IN FRAME CARTON FOR FRAME ASSEMBLY

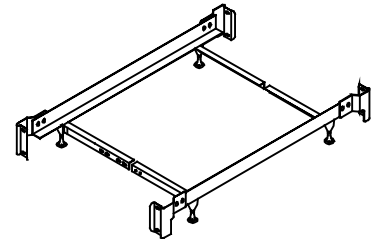

TWIN - FULL BED FRAME FULLY ASSEMBLED
NOTE: SEE INSTRUCTIONS INCLUDED IN FRAME CARTON FOR FRAME ASSEMBLY

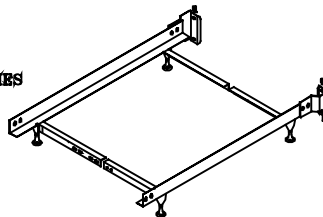

TWIN - FULL HEADBOARD ONLY FRAME FULLY ASSEMBLED
NOTE: SEE INSTRUCTIONS INCLUDED IN FRAME CARTON FOR FRAME ASSEMBLY

FOR ASSISTANCE IN ASSEMBLY ONLY OF THIS PRODUCT. CALL OUR HELP DESK AT 1-800-324-3415, BETWEEN 8:30 AM & 4:30 PM CENTRAL TIME MONDAY THRU FRIDAY. PLEASE HAVE THE STYLE NUMBER AVAILABLE BEFORE YOU CALL. (STYLE # OR NAME CAN BE FOUND ON PACKING CARTON OR SALES RECEIPT.) OUR PRODUCT IS INSPECTED TO ENSURE IT IS IN GOOD CONDITION. IF YOUR FURNITURE APPEARS TO HAVE BEEN DAMAGED IN SHIPMENT OR YOU ARE IN NEED OF REPLACEMENT PARTS PLEASE CONTACT THE DEALER FROM WHOM YOU PURCHASED THE PRODUCT.

Instruction Sheet

SAVE ALL PACKAGING MATERIALS UNTIL PRODUCT IS FULLY ASSEMBLED. HARDWARE AND SMALL PIECES MAY NOT BE SEEN AND BE ACCIDENTALLY DISCARDED WITH PACKAGING MATERIALS.

FIGURE 1

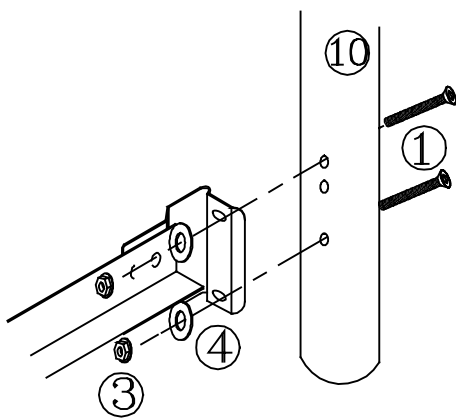
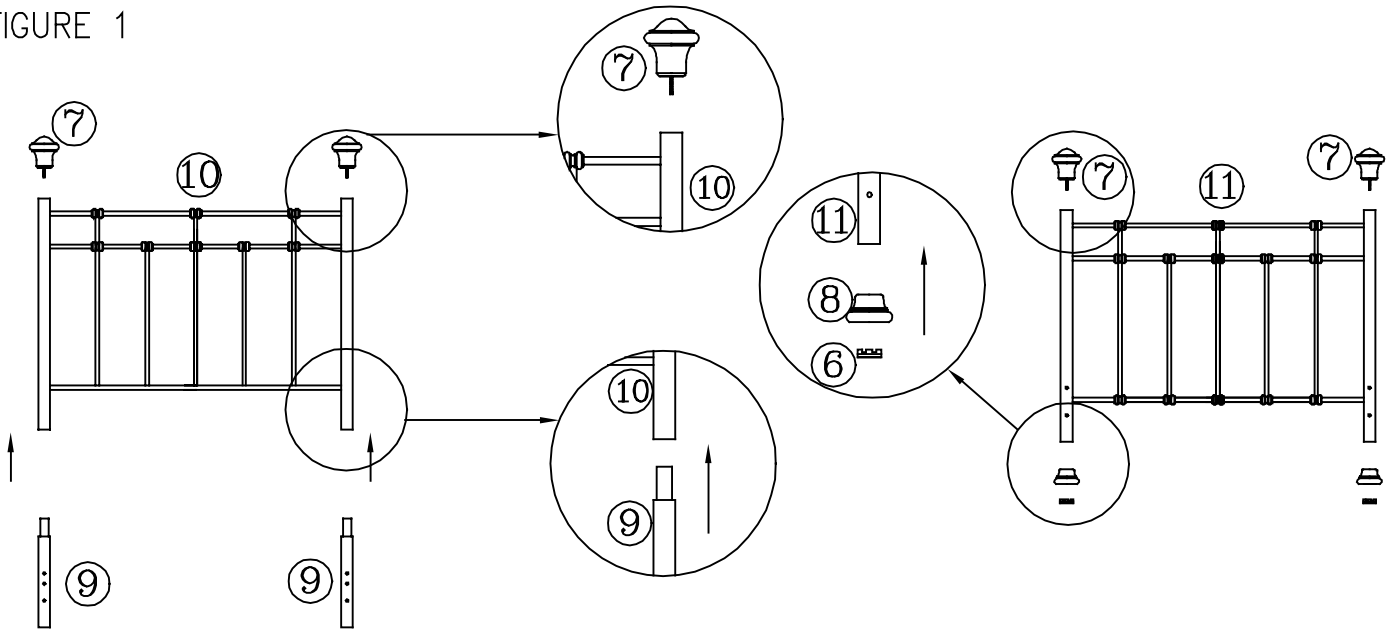

FIGURE 2

Step 1

- Align top reduction of extension legs (9) with bottom of headboard posts. (See Figure 1) Make sure the 3 holes on extension legs are perpendicular to headboard panel.
- Now carefully insert extension legs (9) into bottom of headboard (10) posts.
- Screw in finials (7) on top of headboard (10) and footboard (11) posts. (See Figure 1)
- Slide foot castings (8) onto bottom of footboard (11) posts. Insert plastic glide (6) into bottom of foot casting.

Step 2

- Place headboard and frame in desired location in room.
- Place 2 screws (1) through holes located in leg (9). (See Figure 2)
- Align bed frame bracket over screws.
- Place a flat washer (4) and a nut (3) on each screw. Hand-tighten, DO NOT TIGHTEN screws all the way.
- Repeat on other side of headboard.
- Tighten all screws securely using the Allen wrench (5).

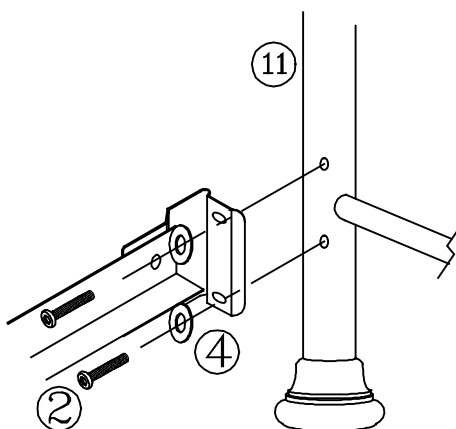

FIGURE 3

Step 3

- Position footboard panel (11) and align holes in the post with holes in the frame bracket. (See figure 3)
- Place flat washer (4) on each screw (2). Insert through bracket and into post. Hand-tighten, DO NOT TIGHTEN screws all the way.
- Repeat on other side of footboard panel.
- Tighten all screws securely using the Allen wrench (5).

Fashion Bed Group

A Division of Leggett & Platt Incorporated
5950 West 51st Street - Chicago, IL 60638









Parts List For Dexter Twin Bed

BED CARTON

- (10) HEADBOARD PANEL
- (11) FOOTBOARD PANEL

PART #351501 HARDWARE BAG FOR BED ATTACHMENT TO FRAME

- (1) 1/4-20 2 1/4" COUNTER SUNK ALLEN HEAD SCREW-4
- (2) 1/4-20 1" FLAT ALLEN HEAD SCREW-4
- (3) 5/8" OD FLAT WASHER-8
- (4) 1/4-20 HEX NUT-4
- (5) ALLEN WRENCH
- (6) PLASTIC GLIDE-4
- (7) FINIAL-4
- (8) FOOT CASTING-2
- (9) LEG EXTENSION-2

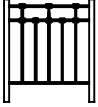
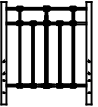
| | | | | | | |
|--|---|---|---|--|---|--|
| 1  | 2  | 3  | 4  | 5  | 6  | 7  |
| 8  | 9  | | 10  | | 11  | |

PRODUCT FULLY ASSEMBLED

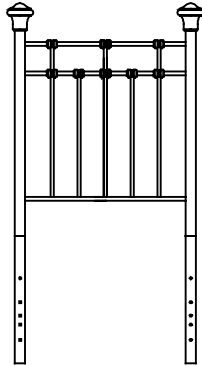

HEADBOARD PANEL

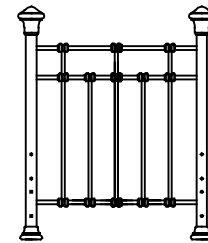

FOOTBOARD PANEL

Twin Size Options

- 1st. USE LINK SPRING (UPPER CONNECTION) FOR TRUNDLE APPLICATION (ONLY A MATTRESS).
- 2nd. USE FRAME (LOWER CONNECTION) W/BOX SPRING AND MATTRESS.

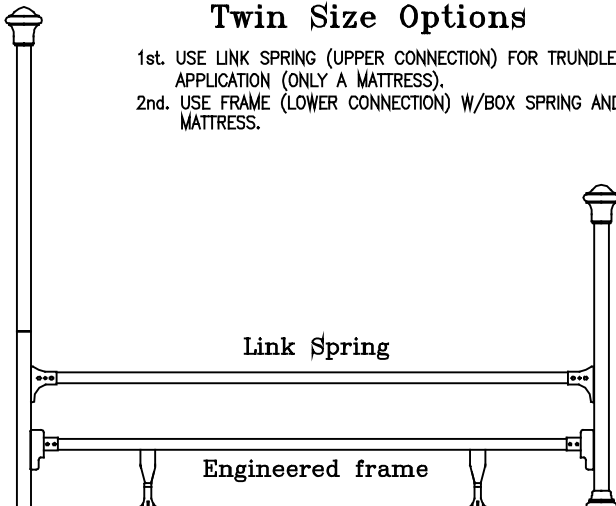

Link Spring

Engineered frame

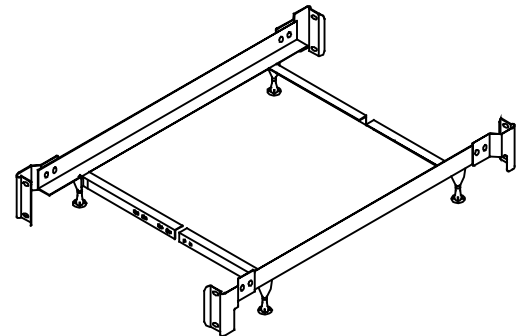

TWIN - FULL FRAME FULLY ASSEMBLED

NOTE: SEE INSTRUCTIONS INCLUDED IN FRAME CARTON FOR FRAME ASSEMBLY

OPTIONAL

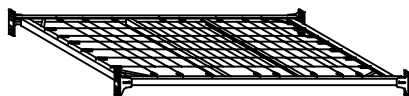

MATTRESS LINK SPRING FULLY ASSEMBLED

OPTIONAL

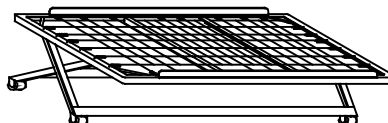

POP-UP TRUNDLE

FOR ASSISTANCE IN ASSEMBLY ONLY OF THIS PRODUCT. CALL OUR HELP DESK AT 1-800-324-3415, BETWEEN 8:30 AM & 4:30 PM CENTRAL TIME MONDAY THRU FRIDAY. PLEASE HAVE THE STYLE NUMBER AVAILABLE BEFORE YOU CALL. (STYLE # OR NAME CAN BE FOUND ON PACKING CARTON OR SALES RECEIPT.) OUR PRODUCT IS INSPECTED TO ENSURE IT IS IN GOOD CONDITION. IF YOUR FURNITURE APPEARS TO HAVE BEEN DAMAGED IN SHIPMENT OR YOU ARE IN NEED OF REPLACEMENT PARTS PLEASE CONTACT THE DEALER FROM WHOM YOU PURCHASED THE PRODUCT.

Instruction Sheet

SAVE ALL PACKAGING MATERIALS UNTIL PRODUCT IS FULLY ASSEMBLED. HARDWARE AND SMALL PIECES MAY NOT BE SEEN AND BE ACCIDENTALLY DISCARDED WITH PACKAGING MATERIALS.

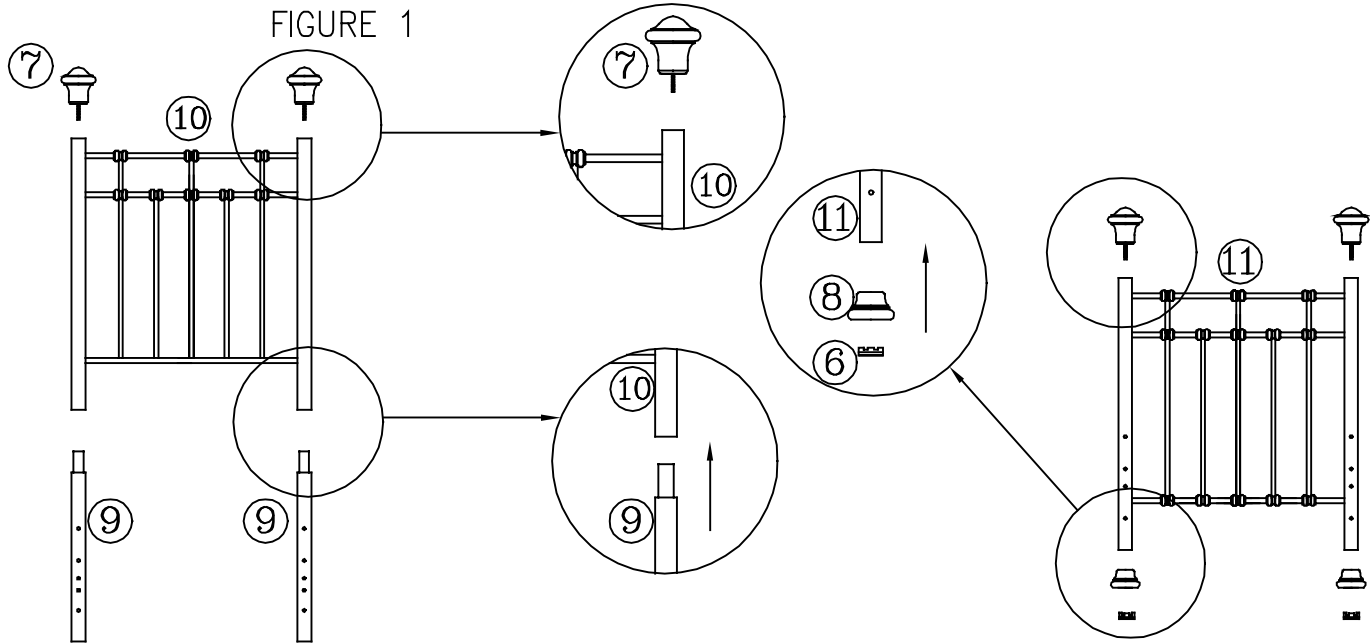
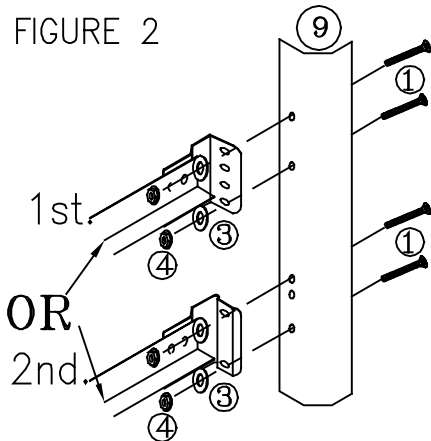

FIGURE 2



Step 1

- Align top reduction of extension legs (9) with bottom of headboard posts. (See Figure 1) Make sure the 3 holes on extension legs are perpendicular to headboard panel.
- Now carefully insert extension legs (9) into bottom of headboard (10) posts.
- Screw in finials (7) on top of headboard (10) and footboard (11) posts. (See Figure 1)
- Slide foot castings (8) onto bottom of footboard (11) posts. Insert plastic glide (6) into bottom of foot casting.

Step 2

- Note: YOU HAVE TWO ASSEMBLY OPTIONS WITH A TWIN SIZE:
1st. USE UPPER ASSEMBLY IF USING AS A TRUNDLE UNIT WITH MATTRESS ONLY.
2nd. USE LOWER FRAME ASSEMBLY IF USING BOX SPRING & MATTRESS.

FIGURE 3

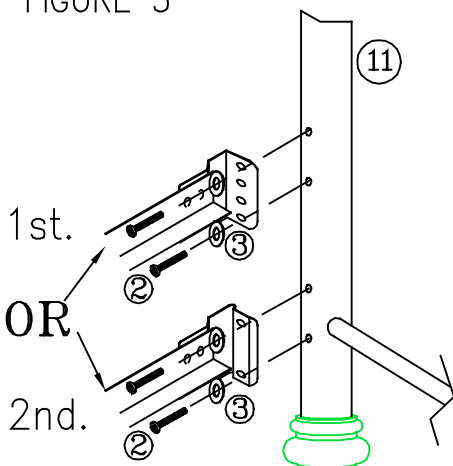

Step 3

- Place headboard and frame in desired location in room.
 - Place 2 screws (1) through holes located in extension leg (9). (See Fig. 2)
 - Align bed frame bracket over screws.
 - Place a washer (3) and then a nut (4) on each screw. Hand-tighten, DO NOT TIGHTEN screws all the way.
 - Repeat on other side of headboard.
 - Tighten all screws securely using the Allen wrench (5).
- Position footboard panel (11) and align holes in the post with holes in the frame bracket. (See Fig. 3)
Note: Use the same hole position that you used for the headboard attachment of to the frame or link spring.
- Place washer (3) on each screw (2). Insert through bracket and into footboard post. (See Fig. 3) Hand-tighten, DO NOT TIGHTEN screws all the way.
 - Repeat on other side of footboard panel.
 - Tighten all screws securely using the Allen wrench (5).