

Fashion Bed Group

A Division of Leggett & Platt Incorporated
5950 West 51st Street - Chicago, IL 60638









Chester Duo Parts List

CARTON

(11) PANEL

PART #302301 HARDWARE BAG FOR BED ATTACHMENT TO FRAME

- (1) 1/4-20 X 2 1/4" FLAT ALLEN HEAD SCREW-4
- (2) 1/4-20 X 3/4" FLAT ALLEN HEAD SCREW -4
- (3) 5/8" OD FLAT METAL WASHER -4
- (4) 1/4-20 HEX NUT -4
- (5) ALLEN WRENCH -1
- (6) OPEN WRENCH -1
- (7) 1 1/2" DIA. PLASTIC GLIDE - 2 # 362302
- (8) SMALL FINIAL -2 #362304
- (9) LARGE FINIAL -2 #362405
- (10) 1 1/2" DIA. LEG EXT -2 #362303

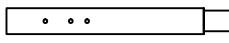
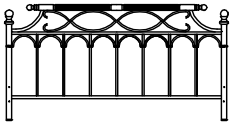
1 	2 	3 	4 	5 
6 	7 	8 	9 	
10 		11 		

PRODUCT FULLY ASSEMBLED

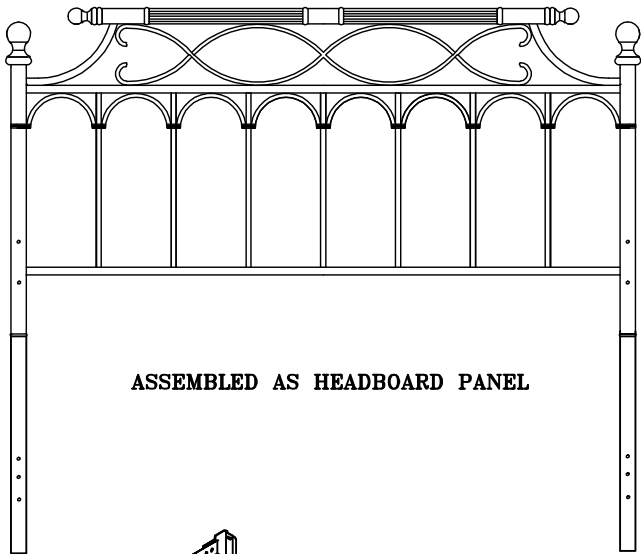

ASSEMBLED AS HEADBOARD PANEL

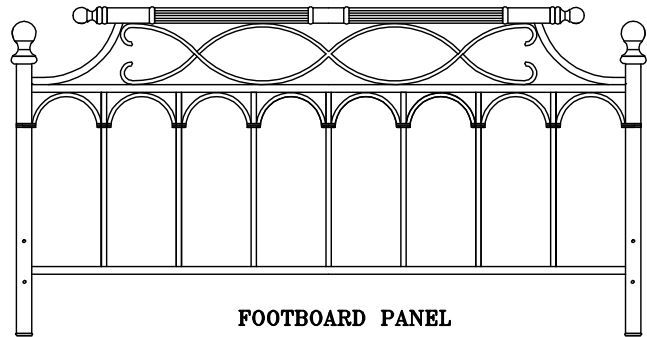

FOOTBOARD PANEL

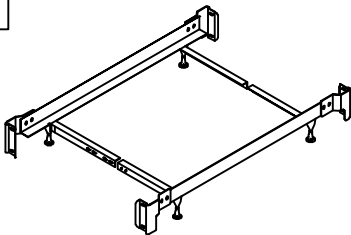

TWIN - FULL BED FRAME FULLY ASSEMBLED

NOTE: SEE INSTRUCTIONS INCLUDED IN FRAME CARTON FOR FRAME ASSEMBLY

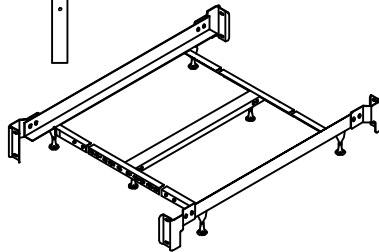

QUEEN - KING BED FRAME FULLY ASSEMBLED

NOTE: SEE INSTRUCTIONS INCLUDED IN FRAME CARTON FOR FRAME ASSEMBLY

FOR ASSISTANCE IN ASSEMBLY ONLY OF THIS PRODUCT. CALL OUR HELP DESK AT 1-800-324-3415, BETWEEN 8:30 AM & 4:30 PM CENTRAL TIME MONDAY THRU FRIDAY. PLEASE HAVE THE STYLE NUMBER AVAILABLE BEFORE YOU CALL. (STYLE # OR NAME CAN BE FOUND ON PACKING CARTON OR SALES RECEIPT.) OUR PRODUCT IS INSPECTED TO ENSURE IT IS IN GOOD CONDITION. IF YOUR FURNITURE APPEARS TO HAVE BEEN DAMAGED IN SHIPMENT OR YOU ARE IN NEED OF REPLACEMENT PARTS PLEASE CONTACT THE DEALER FROM WHOM YOU PURCHASED THE PRODUCT.

Instruction Sheet

SAVE ALL PACKAGING MATERIALS UNTIL PRODUCT IS FULLY ASSEMBLED. HARDWARE AND SMALL PIECES MAY NOT BE SEEN AND BE ACCIDENTALLY DISCARDED WITH PACKAGING MATERIALS.

FIGURE 1

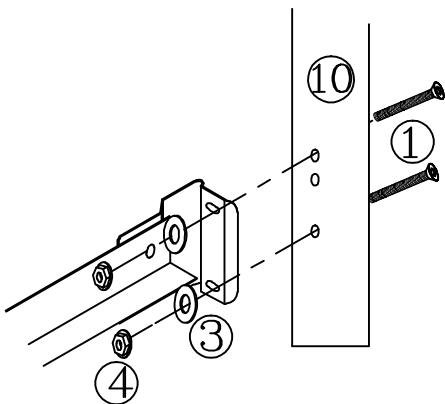
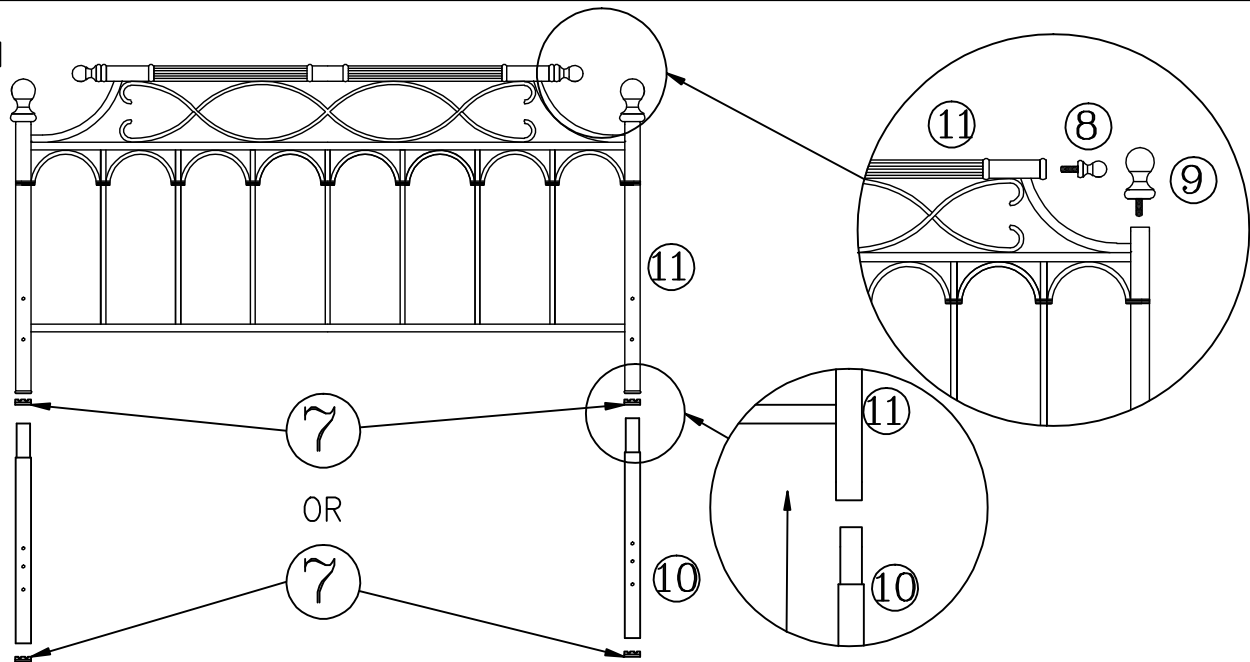

FIGURE 2

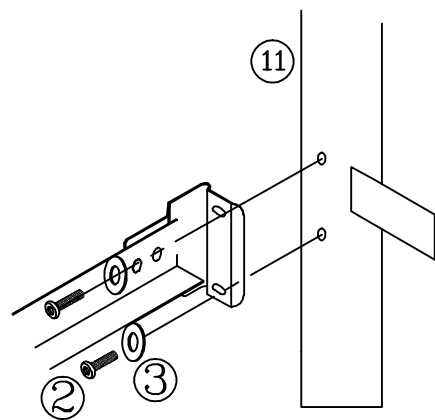

FIGURE 3

NOTE: This product can be used as Headboard only or as Headboard/Footboard bed. Insert plastic glide (7) into leg extension (10) for headboard assembly. For footboard assembly insert plastic glide (7) into bottom of panel (11) posts. See Figure 1

Step 1 Headboard assembly

- Align top reduction of extension leg (10) with bottom of panel post (11). (See Figure 1) Make sure the 3 holes on extension legs are perpendicular to panel.
- Now carefully insert extension leg (10) into bottom of panel (11) post.
- Repeat on other side of panel.
- Secure small finial (8) and large finial (9) on top rail and post of panel (11). (See Figure 1)

Step 2

- Place headboard and frame in desired location in room.
- Place 2 screws (1) through holes located in leg (10). (See Figure 2)
- Align bed frame bracket over screws.
- Place a flat washer (3) first and then a hex nut (4) on each screw. Hand-tighten, DO NOT TIGHTEN screws all the way.
- Repeat on other side of headboard.
- Tighten all screws securely using the Allen wrench (5) and open wrench (6).

Step 3 Footboard Assembly

- Discard Leg extension (10) for footboard attachment to frame.
- Position panel (11) and align holes in the post with holes in the frame bracket. (See Figure 3)
- Place washer (3) over on each screw (2). Insert through bracket and into panel (11) post. Hand-tighten, DO NOT TIGHTEN screws all the way.
- Repeat on other side of footboard panel.
- Tighten all screws securely using the Allen wrench.