

Fashion Bed Group

A Division of Leggett & Platt Incorporated
5950 West 51st Street - Chicago, IL 60638

Parts List For Adelaide Bed

BED CARTON

- (8) HEADBOARD PANEL
- (9) FOOTBOARD PANEL

PART #345701 HARDWARE BAG FOR BED ATTACHMENT TO FRAME

- (1) 1/4-20 2 3/4" COUNTERSUNK ALLEN HEAD SCREW-4
- (2) 1/4-20 1" FLAT ALLEN HEAD SCREW-4
- (3) 1/4-20 HEX NUT-4
- (4) 5/8" OD FLAT WASHER-8
- (5) ALLEN WRENCH
- (6) 1/4" ID LOCK WASHER-4
- (7) OPEN WRENCH-1
- (8) LEG EXTENSION-2

HEADBOARD CARTON

- (8) HEADBOARD PANEL

PART #345702 HARDWARE BAG FOR HEADBOARD ATTACHMENT TO FRAME

- (1) 1/4-20 2 3/4" COUNTERSUNK ALLEN HEAD SCREW-4
- (2) 1/4-20 HEX NUT-4
- (3) 5/8" OD FLAT WASHER-4
- (4) ALLEN WRENCH
- (5) 1/4" ID LOCK WASHER-4
- (6) OPEN WRENCH-1
- (7) LEG EXTENSION-2

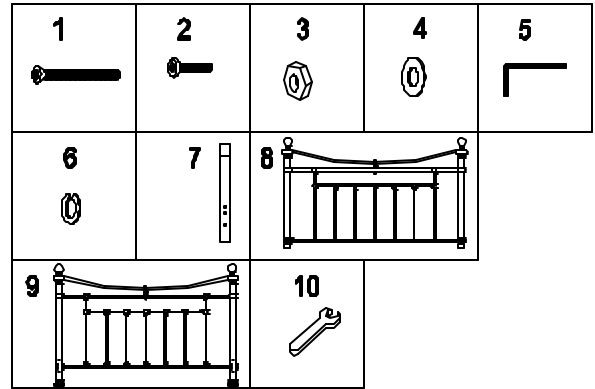

PRODUCT FULLY ASSEMBLED

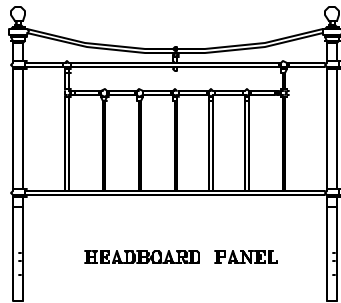

HEADBOARD PANEL

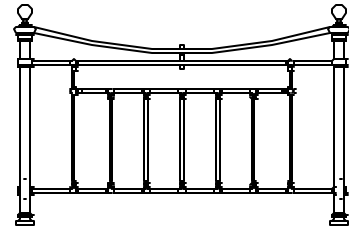

FOOTBOARD PANEL

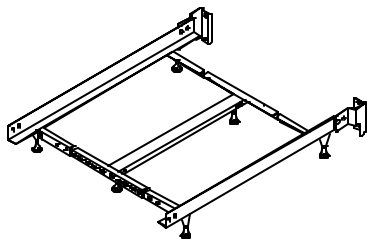

QUEEN - KING HEADBOARD ONLY FRAME FULLY ASSEMBLED FRAMES
NOTE: SEE INSTRUCTIONS INCLUDED IN FRAME CARTON FOR FRAME ASSEMBLY

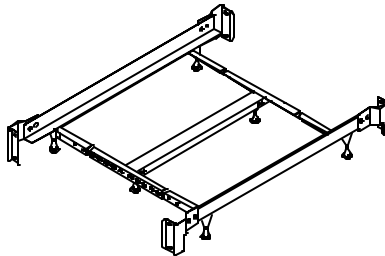

QUEEN - KING BED FRAME FULLY ASSEMBLED
NOTE: SEE INSTRUCTIONS INCLUDED IN FRAME CARTON FOR FRAME ASSEMBLY

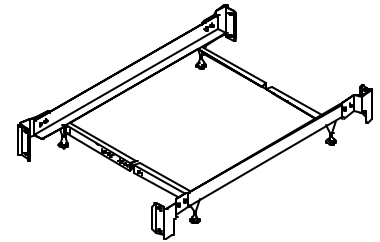

TWIN - FULL BED FRAME FULLY ASSEMBLED
NOTE: SEE INSTRUCTIONS INCLUDED IN FRAME CARTON FOR FRAME ASSEMBLY

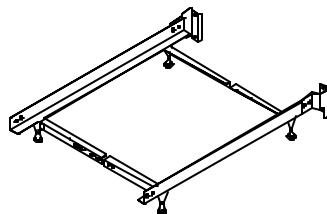

TWIN - FULL HEADBOARD ONLY FRAME FULLY ASSEMBLED
NOTE: SEE INSTRUCTIONS INCLUDED IN FRAME CARTON FOR FRAME ASSEMBLY

FOR ASSISTANCE IN ASSEMBLY ONLY OF THIS PRODUCT. CALL OUR HELP DESK AT 1-800-324-3415, BETWEEN 8:30 AM & 4:30 PM CENTRAL TIME MONDAY THRU FRIDAY. PLEASE HAVE THE STYLE NUMBER AVAILABLE BEFORE YOU CALL. (STYLE # OR NAME CAN BE FOUND ON PACKING CARTON OR SALES RECEIPT.) OUR PRODUCT IS INSPECTED TO ENSURE IT IS IN GOOD CONDITION. IF YOUR FURNITURE APPEARS TO HAVE BEEN DAMAGED IN SHIPMENT OR YOU ARE IN NEED OF REPLACEMENT PARTS PLEASE CONTACT THE DEALER FROM WHOM YOU PURCHASED THE PRODUCT.

Instruction Sheet

SAVE ALL PACKAGING MATERIALS UNTIL PRODUCT IS FULLY ASSEMBLED. HARDWARE AND SMALL PIECES MAY NOT BE SEEN AND BE ACCIDENTALLY DISCARDED WITH PACKAGING MATERIALS.

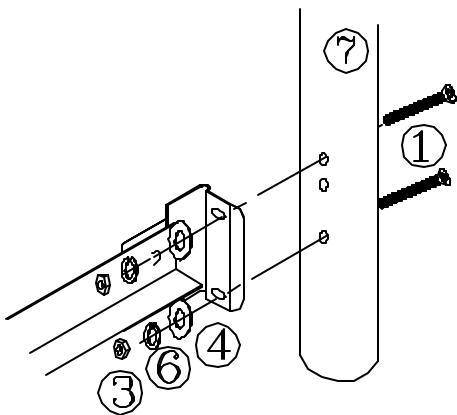
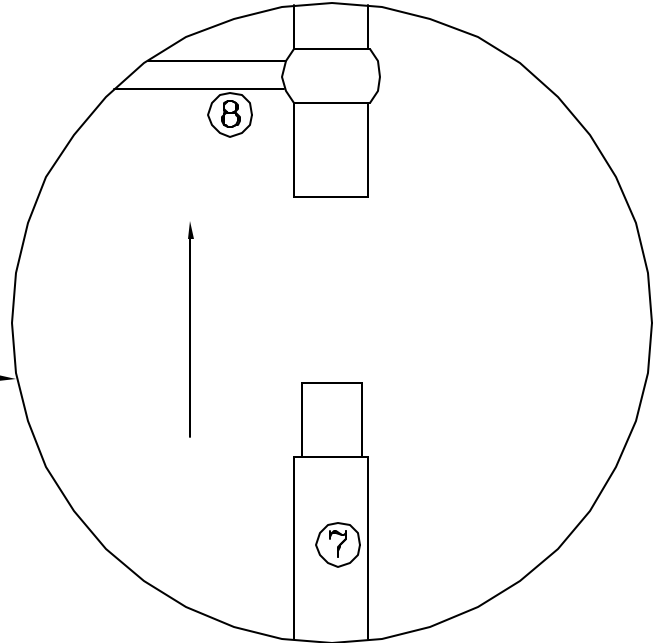
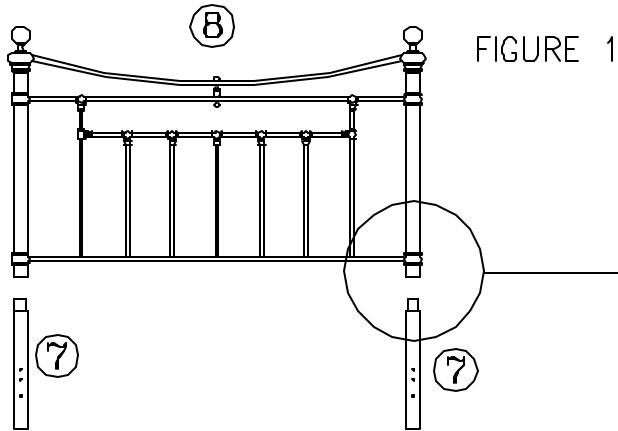

FIGURE 2

Step 1

- Align top reduction of extension legs (7) with bottom of headboard posts. (See Figure 1) Make sure the 3 holes on extension legs are perpendicular to headboard panel.
- Now carefully insert extension legs (7) into bottom of headboard (8) posts.

Step 2

- Place headboard and frame in desired location in room.
- Place 2 screws (1) through holes located in leg (7). (See Figure 2)
- Align bed frame bracket over screws.
- Place a flat washer (4) first, a lock washer (6) and then a nut (3) on each screw. Hand-tighten, DO NOT TIGHTEN screws all the way.
- Repeat on other side of headboard.
- Tighten all screws securely using the Allen wrench and open wrench.

Step 3

- Position footboard (9) panel and align holes in the post with holes in the frame bracket. (See figure 3)
- Place a lock washer (6) and a flat washer (4) on each screw (2). Insert through bracket and into post. Hand-tighten, DO NOT TIGHTEN screws all the way.
- Repeat on other side of footboard panel.
- Tighten all screws securely using the Allen wrench.

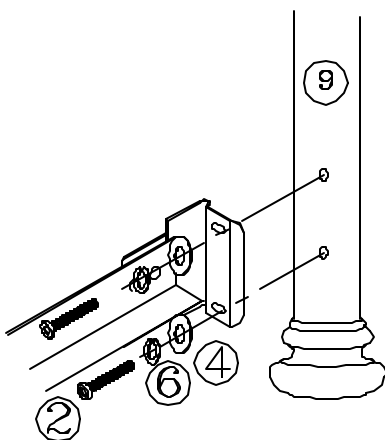

FIGURE 3

Fashion Bed Group

A Division of Leggett & Platt Incorporated
5950 West 51st Street - Chicago, IL 60638

Parts List For Adelaide Twin bed

BED CARTON

- (9) HEADBOARD PANEL
- (10) FOOTBOARD PANEL

PART #346701 HARDWARE BAG FOR BED

- (1) 1/4-20 2 3/4" COUNTER SUNK ALLEN HEAD SCREW-4
- (2) 1/4-20 1" FLAT ALLEN HEAD SCREW-4
- (3) 1/4-20 HEX NUT-4
- (4) 1/4" ID LOCK WASHER-8
- (5) 5/8" OD FLAT STEEL WASHER-8
- (6) ALLEN WRENCH
- (7) OPEN WRENCH
- (8) LEG EXTENSION-2

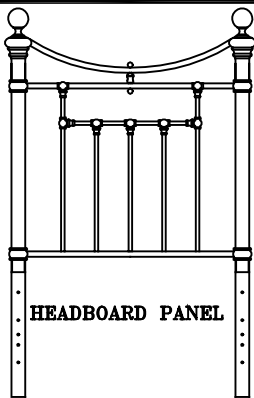
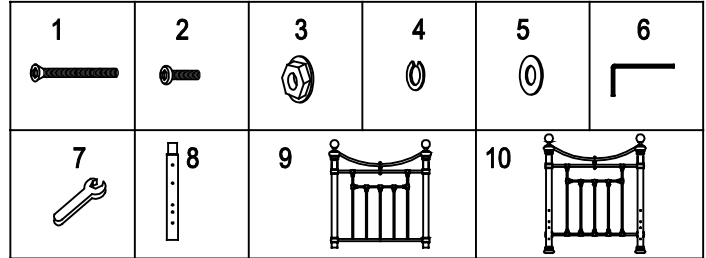

HEADBOARD PANEL

PRODUCT FULLY ASSEMBLED

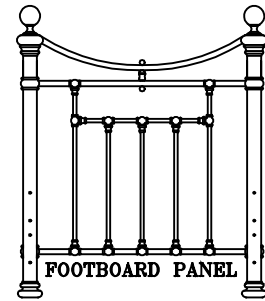

FOOTBOARD PANEL

Twin Size Options

- 1st. USE LINK SPRING (UPPER CONNECTION) FOR TRUNDLE APPLICATION (ONLY A MATTRESS).
- 2nd. USE FRAME (LOWER CONNECTION) W/BOX SPRING AND MATTRESS.

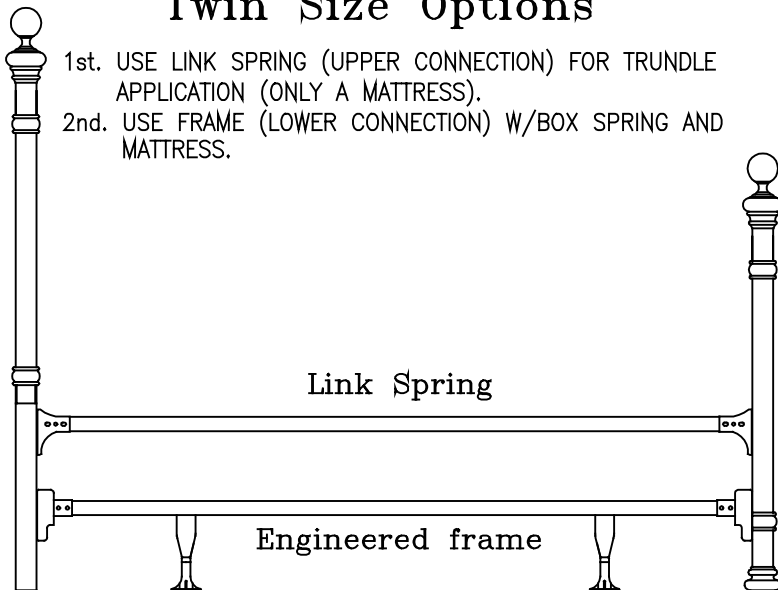

Link Spring

Engineered frame

PRODUCT FULLY ASSEMBLED

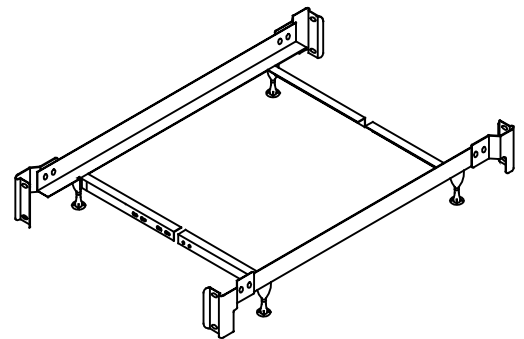

TWIN - FULL FRAME FULLY ASSEMBLED

NOTE: SEE INSTRUCTIONS INCLUDED IN FRAME CARTON FOR FRAME ASSEMBLY

OPTIONAL

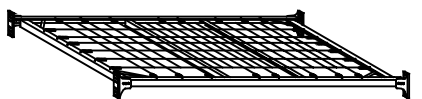

MATTRESS LINK SPRING FULLY ASSEMBLED

OPTIONAL

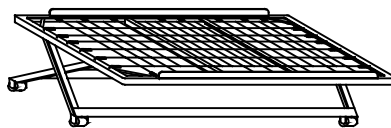

POP-UP TRUNDLE

7-15-05

3468

FOR ASSISTANCE IN ASSEMBLY ONLY OF THIS PRODUCT, CALL OUR HELP DESK AT 1-800-324-3415, BETWEEN 8:30 AM & 4:30 PM CENTRAL TIME MONDAY THRU FRIDAY. PLEASE HAVE THE STYLE NUMBER AVAILABLE BEFORE YOU CALL. (STYLE # OR NAME CAN BE FOUND ON PACKING CARTON OR SALES RECEIPT.) OUR PRODUCT IS INSPECTED TO ENSURE IT IS IN GOOD CONDITION. IF YOUR FURNITURE APPEARS TO HAVE BEEN DAMAGED IN SHIPMENT OR YOU ARE IN NEED OF REPLACEMENT PARTS PLEASE CONTACT THE DEALER FROM WHOM YOU PURCHASED THE PRODUCT.

Instruction Sheet

SAVE ALL PACKAGING MATERIALS UNTIL PRODUCT IS FULLY ASSEMBLED. HARDWARE AND SMALL PIECES MAY NOT BE SEEN AND BE ACCIDENTALLY DISCARDED WITH PACKAGING MATERIALS.

FIGURE 1

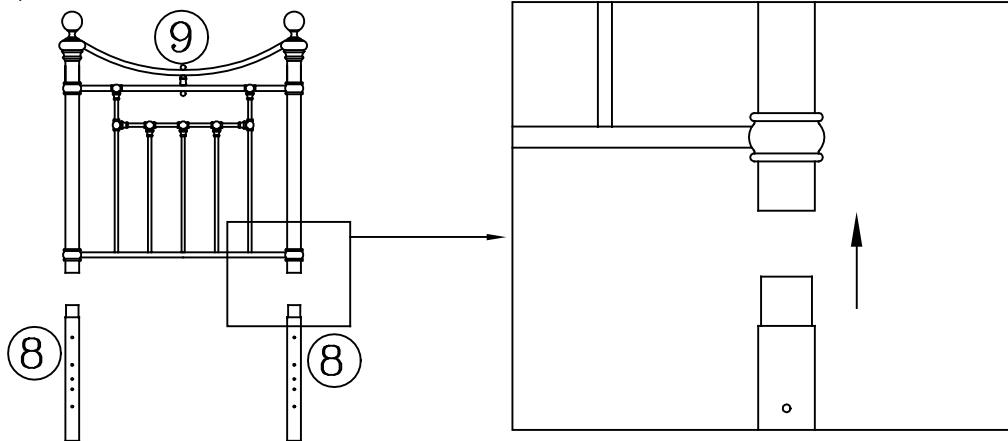
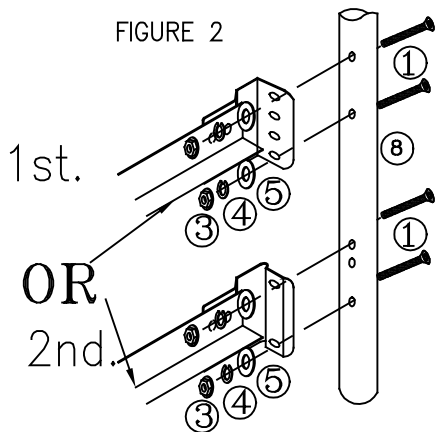

FIGURE 2



Step 1

- Align top reduction of extension legs (8) with bottom of headboard (9) posts. (See Figure 1) Make sure the 5 holes on extension legs are perpendicular to headboard panel.
- Now carefully insert extension legs (8) into bottom of posts.

Step 2

- Note: YOU HAVE TWO ASSEMBLY OPTIONS WITH A TWIN SIZE:
1st. USE UPPER ASSEMBLY IF USING AS A TRUNDLE UNIT WITH MATTRESS ONLY.
2nd. USE LOWER FRAME ASSEMBLY IF USING BOX SPRING & MATTRESS.
- Place headboard and frame in desired location in room.
- Place 2 screws (1) through holes located in leg (8). (See Figure 2)
- Align frame bracket over screws.
- First place a flat washer (5), then a lock washer (4) and a nut (3) on each screw. Hand-tighten, DO NOT TIGHTEN screws all the way.
- Repeat on other side of headboard.
- Tighten all screws securely using the Allen wrench and open wrench.

FIGURE 3

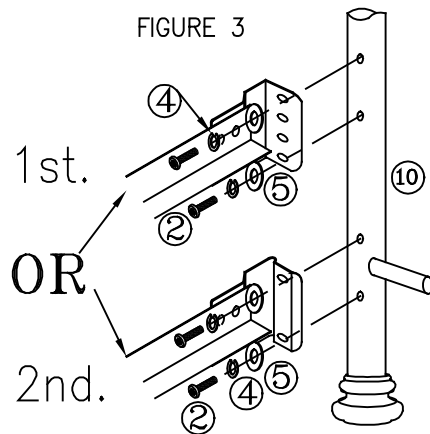

Step 3

- Position footboard panel and align holes in the post with holes in the metal bracket. See figure 3
Note: Use the same hole position that you used for the headboard attachment of to the frame or link spring.
- Place a lock washer (4) and a flat washer (5) on each screw (2). Insert through bracket and into assembly holes in posts. Hand-tighten,
- Repeat on other side of foot board panel.
- Tighten all screws securely using the Allen wrench.